

CHAPTER 5 GRAVITATIONAL FIELD AND POTENTIAL

5.1 Introduction.

This chapter deals with the calculation of gravitational fields and potentials in the vicinity of various shapes and sizes of massive bodies. The reader who has studied electrostatics will recognize that this is all just a repeat of what he or she already knows. After all, the force of repulsion between two electric charges q_1 and q_2 a distance r apart *in vacuo* is

$$\frac{q_1 q_2}{4\pi\epsilon_0 r^2},$$

where ϵ_0 is the permittivity of free space, and the attractive force between two masses M_1 and M_2 a distance r apart is

$$\frac{GM_1 M_2}{r^2},$$

where G is the gravitational constant, or, phrased another way, the *repulsive* force is

$$-\frac{GM_1 M_2}{r^2}.$$

Thus all the equations for the fields and potentials in gravitational problems are the same as the corresponding equations in electrostatics problems, provided that the charges are replaced by masses and $4\pi\epsilon_0$ is replaced by $-1/G$.

I can, however, think of two differences. In the electrostatics case, we have the possibility of both positive and negative charges. As far as I know, only positive masses exist. This means, among other things, that we do not have “gravitational dipoles” and all the phenomena associated with polarization that we have in electrostatics.

The second difference is this. If a particle of mass m and charge q is placed in an electric field \mathbf{E} , it will experience a force $q\mathbf{E}$, and it will accelerate at a rate and in a direction given by $q\mathbf{E}/m$. If the same particle is placed in a gravitational field \mathbf{g} , it will experience a force $m\mathbf{g}$ and an acceleration $m\mathbf{g}/m = \mathbf{g}$, irrespective of its mass or of its charge. All masses and all charges in the same gravitational field accelerate at the same rate. This is not so in the case of an electric field.

I have some sympathy for the idea of introducing a “rationalized” gravitational constant Γ , given by $\Gamma = 1/(4\pi G)$, in which case the gravitational formulas would look even more like the SI (rationalized MKSA) electrostatics formulas, with 4π appearing in problems with spherical symmetry, 2π in problems with cylindrical symmetry, and no π in

problems involving uniform fields. This is unlikely to happen, so I do not pursue the idea further here.

5.2 Gravitational Field.

The region around a gravitating body (by which I merely mean a mass, which will attract other masses in its vicinity) is a *gravitational field*. Although I have used the words “around” and “in its vicinity”, the field in fact extends to infinity. All massive bodies (and by “massive” I mean any body having the property of mass, however little) are surrounded by a gravitational field, and all of us are immersed in a gravitational field.

If a test particle of mass m is placed in a gravitational field, it will experience a *force* (and, if released and subjected to no additional forces, it will *accelerate*). This enables us to define quantitatively what we mean by the *strength* of a gravitational field, which is merely the *force experience by unit mass* placed in the field. I shall use the symbol \mathbf{g} for the gravitational field, so that the force \mathbf{F} on a mass m situated in a gravitational field \mathbf{g} is

$$\mathbf{F} = m\mathbf{g}. \quad 5.2.1$$

It can be expressed in newtons per kilogram, N kg^{-1} . If you work out the *dimensions* of \mathbf{g} , you will see that it has dimensions LT^{-2} , so that it can be expressed equivalently in m s^{-2} . Indeed, as pointed out in section 5.1, the mass m (or indeed any other mass) will accelerate at a rate g in the field, and the strength of a gravitational field is simply equal to the rate at which bodies placed in it will accelerate.

Very often, instead of using the expression “strength of the gravitational field” I shall use just “the gravitational field” or perhaps the “field strength” or even just the “field”. Strictly speaking, the “gravitational field” means the region of space surrounding a gravitating mass rather than the field strength, but I hope that, when I am not speaking strictly, the context will make it clear.

5.3 Newton’s Law of Gravitation.

Newton noted that the ratio of the centripetal acceleration of the Moon in its orbit around the Earth to the acceleration of an apple falling to the surface of the Earth was inversely as the squares of the distances of Moon and apple from the centre of the Earth. Together with other lines of evidence, this led Newton to propose his universal law of gravitation:

Every particle in the Universe attracts every other particle with a force that is proportional to the product of their masses and inversely proportional to the square of the distance between them. In symbols:

$$F = \frac{GM_1M_2}{r^2}. \quad \text{N} \quad 5.3.1$$

Here, G is the *Universal Gravitational Constant*. The word “universal” implies an assumption that its value is the same anywhere in the Universe, and the word “constant” implies that it does not vary with time. We shall here accept and adopt these assumptions, while noting that it is a legitimate cosmological question to consider what implications there may be if either of them is not so.

Of all the fundamental physical constants, G is among those whose numerical value has been determined with least precision. Its currently accepted value is $6.6726 \times 10^{-11} \text{ N m}^2 \text{ kg}^{-2}$. It is worth noting that, while the product GM for the Sun is known with very great precision, the mass of the Sun is not known to any higher degree of precision than that of the gravitational constant.

Exercise. Determine the *dimensions* (in terms of M, L and T) of the gravitational constant. Assume that the period of pulsation of a variable star depends on its mass, its average radius and on the value of the gravitational constant, and show that the period of pulsation must be inversely proportional to the square root of its average density.

The gravitational field is often held to be the weakest of the four forces of nature, but to aver this is to compare incomparables. While it is true that the electrostatic force between two electrons is far, far greater than the gravitational force between them, it is equally true that the gravitational force between Sun and Earth is far, far greater than the electrostatic force between them. This example shows that it makes no sense merely to state that electrical forces are stronger than gravitational forces. Thus any statement about the relative strengths of the four forces of nature has to be phrased with care and precision.

5.4 *The Gravitational Fields of Various Bodies.*

In this section we calculate the fields near various shapes and sizes of bodies, much as one does in an introductory electricity course. Some of this will not have much direct application to celestial mechanics, but it will serve as good introductory practice in calculating fields and, later, potentials.

5.4.1 *Field of a Point Mass.*

Equation 5.3.1, together with the definition of field strength as the force experienced by unit mass, means that the field at a distance r from a point mass M is

$$g = \frac{GM}{r^2} \quad \text{N kg}^{-1} \quad \text{or} \quad \text{m s}^{-2} \quad 5.4.1$$

In vector form, this can be written as

$$\mathbf{g} = -\frac{GM}{r^2} \hat{\mathbf{r}} \quad \text{N kg}^{-1} \text{ or } \text{m s}^{-2} \quad 5.4.2$$

Here $\hat{\mathbf{r}}$ is a dimensionless *unit* vector in the radial direction.

It can also be written as

$$\mathbf{g} = -\frac{GM}{r^3} \mathbf{r} \quad \text{N kg}^{-1} \text{ or } \text{m s}^{-2} \quad 5.4.3$$

Here \mathbf{r} is a vector of magnitude r – hence the r^3 in the denominator.

5.4.2 *Field on the Axis of a Ring.*

Before starting, one can obtain a qualitative idea of how the field on the axis of a ring varies with distance from the centre of the ring. Thus, the field at the centre of the ring will be zero, by symmetry. It will also be zero at an infinite distance along the axis. At other places it will not be zero; in other words, the field will first increase, then decrease, as we move along the axis. There will be some distance along the axis at which the field is greatest. We'll want to know where this is, and what is its maximum value.

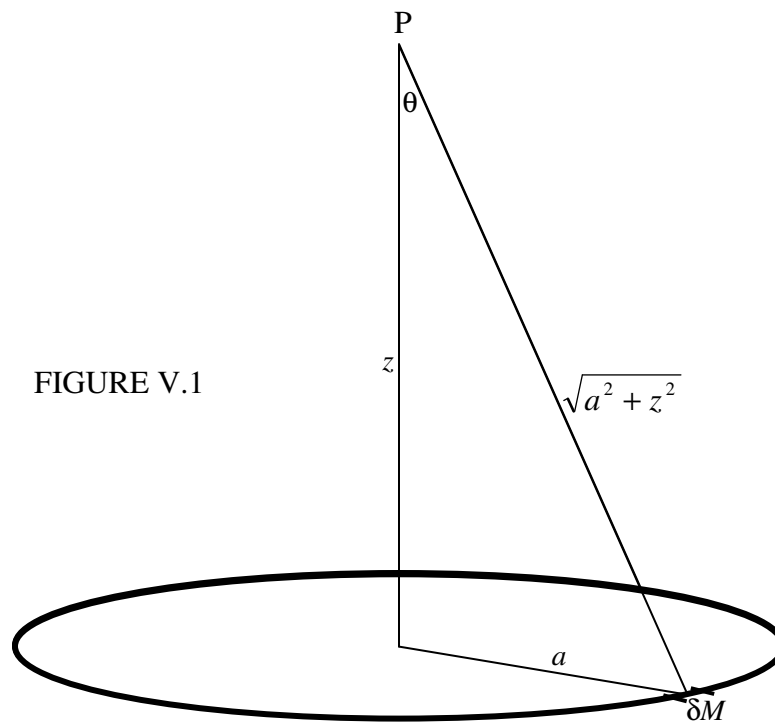

Figure V.1 shows a ring of mass M , radius a . The problem is to calculate the strength of the gravitational field at P. We start by considering a small element of the ring of mass δM . The contribution of this element to the field is

$$\frac{G \delta M}{a^2 + z^2},$$

directed from P towards δM . This can be resolved into a component along the axis (directed to the centre of the ring) and a component at right angles to this. When the contributions to all elements around the circumference of the ring are added, the latter component will, by symmetry, be zero. The component along the axis of the ring is

$$\frac{G \delta M}{a^2 + z^2} \cos \theta = \frac{G \delta M}{a^2 + z^2} \cdot \frac{z}{\sqrt{a^2 + z^2}} = \frac{G \delta M z}{(a^2 + z^2)^{3/2}}.$$

On adding up the contributions of all elements around the circumference of the ring, we find, for the gravitational field at P

$$g = \frac{GMz}{(a^2 + z^2)^{3/2}} \quad 5.4.4$$

directed towards the centre of the ring. This has the property, as expected, of being zero at the centre of the ring and at an infinite distance along the axis. If we express z in units of a , and g in units of GM/a^2 , this becomes

$$g = \frac{z}{(1 + z^2)^{3/2}}. \quad 5.4.5$$

This is illustrated in figure V.2.

Exercise: Show that the field reaches its greatest value of $\frac{\sqrt{12}GM}{9a^2} = \frac{0.385GM}{a^2}$ where $z = a/\sqrt{2} = 0.707a$. Show that the field has half this maximum value where $z = 0.2047a$ and $z = 1.896a$.

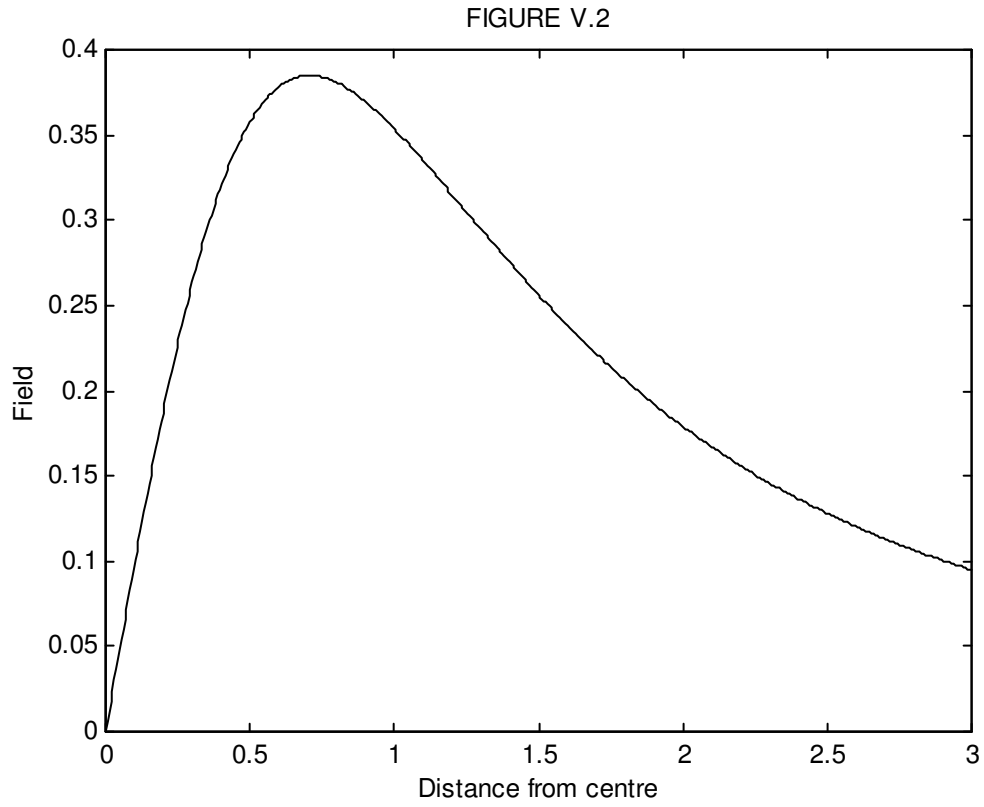

5.4.3 *Plane discs.*

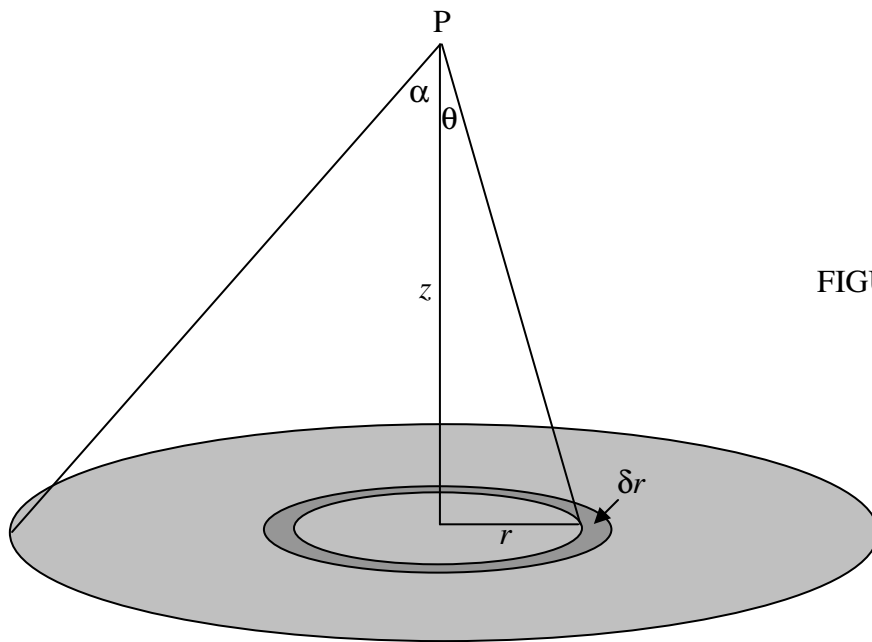

FIGURE V.2A

Consider a disc of surface density (mass per unit area) σ , radius a , and a point P on its axis at a distance z from the disc. The contribution to the field from an elemental annulus, radii r , $r + \delta r$, mass $2\pi\sigma r \delta r$ is (from equation 5.4.1)

$$\delta g = 2\pi G\sigma \frac{z r \delta r}{(z^2 + r^2)^{3/2}}. \quad 5.4.6$$

To find the field from the entire disc, just integrate from $r = 0$ to a , and, if the disc is of uniform surface density, σ will be outside the integral sign. It will be easier to integrate with respect to θ (from 0 to α), where $r = z \tan \theta$. You should get

$$g = 2\pi G\sigma(1 - \cos \alpha), \quad 5.4.7$$

or, with $M = \pi a^2 \sigma$,

$$g = \frac{2GM(1 - \cos \alpha)}{a^2}. \quad 5.4.8$$

Now $2\pi(1 - \cos \alpha)$ is the solid angle ω subtended by the disc at P. (Convince yourself of this – don't just take my word for it.) Therefore

$$g = G\sigma\omega. \quad 5.4.9$$

This expression is also the same for a uniform plane lamina of any shape, for the downward component of the gravitational field. For, consider figure V.3.

The downward component of the field due to the element δA is $\frac{G\sigma \delta A \cos \theta}{r^2} = G\sigma \delta\omega$.

Thus, if you integrate over the whole lamina, you arrive at $G\sigma\omega$.

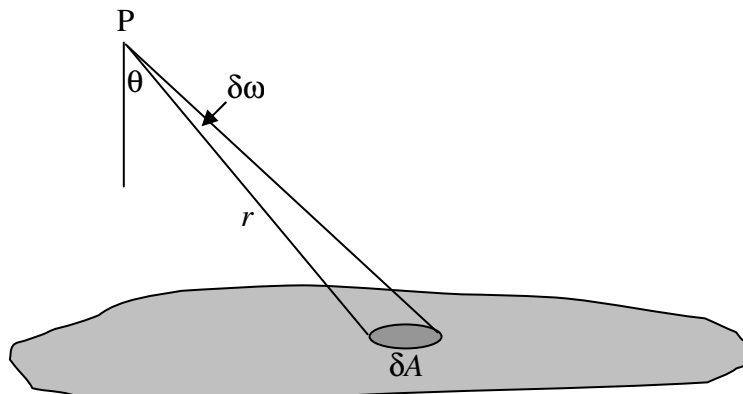
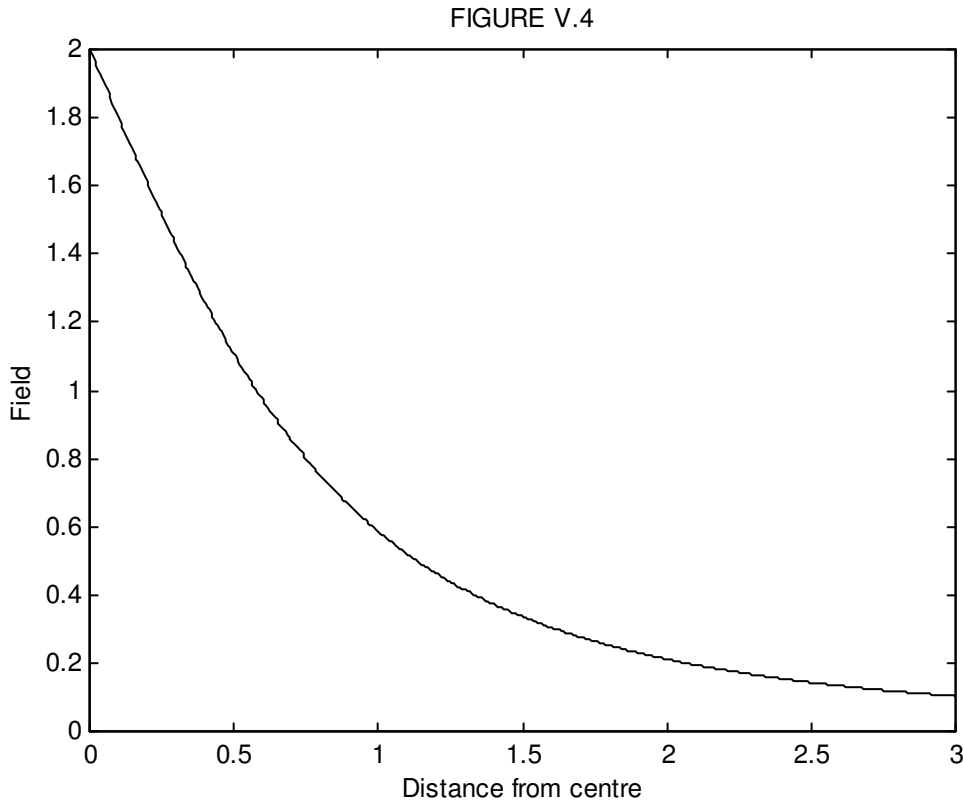

FIGURE V.3

Returning to equation 5.4.8, we can write the equation in terms of z rather than α . If we express g in units of GM/a^2 and z in units of a , the equation becomes

$$g = 2 \left(1 - \frac{z}{\sqrt{1+z^2}} \right). \quad 5.4.10$$

This is illustrated in figure V.4.



The field is greatest immediately above the disc. On the opposite side of the disc, the field changes direction. In the plane of the disc, at the centre of the disc, the field is zero. For more on this, see Subsection 5.4.7.

If you are calculating the field on the axis of a disc that is not of uniform surface density, but whose surface density varies as $\sigma(r)$, you will have to calculate

$$M = 2\pi \int_0^a \sigma(r) r dr \quad 5.4.11$$

and

$$g = 2\pi Gz \int_0^a \frac{\sigma(r) r dr}{(z^2 + r^2)^{3/2}}. \quad 5.4.12$$

You could try, for example, some of the following forms for $\sigma(r)$:

$$\sigma_0 \left(1 - \frac{kr}{a}\right), \quad \sigma_0 \left(1 - \frac{kr^2}{a^2}\right), \quad \sigma_0 \sqrt{1 - \frac{kr}{a}}, \quad \sigma_0 \sqrt{1 - \frac{kr^2}{a^2}}.$$

If you are interested in galaxies, you might want to try modelling a galaxy as a central spherical bulge of density ρ and radius a_1 , plus a disc of surface density $\sigma(r)$ and radius a_2 , and from there you can work your way up to more sophisticated models.

In this section we have calculated the field on the *axis* of a disc. As soon as you move off axis, it becomes *much* more difficult.

Exercise. Starting from equations 5.4.1 and 5.4.10, show that at very large distances along the axis, the fields for a ring and for a disc each become GM/z^2 . All you have to do is to expand the expressions binomially in a/z . The field at a large distance r from any finite object will approach GM/r^2 .

5.4.4 Infinite Plane Laminae.

For the gravitational field due to a uniform infinite plane lamina, all one has to do is to put $\alpha = \pi/2$ in equation 5.4.7 or $\omega = 2\pi$ in equation 5.4.9 to find that the gravitational field is

$$g = 2\pi G\sigma. \tag{5.4.13}$$

This is, as might be expected, independent of distance from the infinite plane. The lines of gravitational field are uniform and parallel all the way from the surface of the lamina to infinity.

Suppose that the surface density of the infinite plane is not uniform, but varies with distance in the plane from some point in the plane as $\sigma(r)$, we have to calculate

$$g = 2\pi Gz \int_0^\infty \frac{\sigma(r) r dr}{(z^2 + r^2)^{3/2}}. \tag{5.4.14}$$

Try it, for example, with $\sigma(r)$ being one of the following:

$$\sigma_0 e^{-kr}, \quad \sigma_0 e^{-k^2 r^2}, \quad \frac{\sigma_0}{1+k^2 r^2}.$$

5.4.5 *Hollow Hemisphere.*

Exercise. Find the field at the centre of the base of a hollow hemispherical shell of mass M and radius a .

5.4.6 *Rods.*

FIGURE V.5

Consider the rod shown in figure V.5, of mass per unit length λ . The field at P due to the element δx is $G\lambda \delta x/r^2$. But $x = h \tan \theta$, $\delta x = h \sec^2 \theta \delta \theta$, $r = h \sec \theta$, so the field at P is $G\lambda \delta \theta/h$. This is directed from P to the element δx .

The x -component of the field due to the whole rod is

$$\frac{G\lambda}{h} \int_{\alpha}^{\beta} \sin \theta d\theta = \frac{G\lambda}{h} (\cos \alpha - \cos \beta). \quad 5.4.15$$

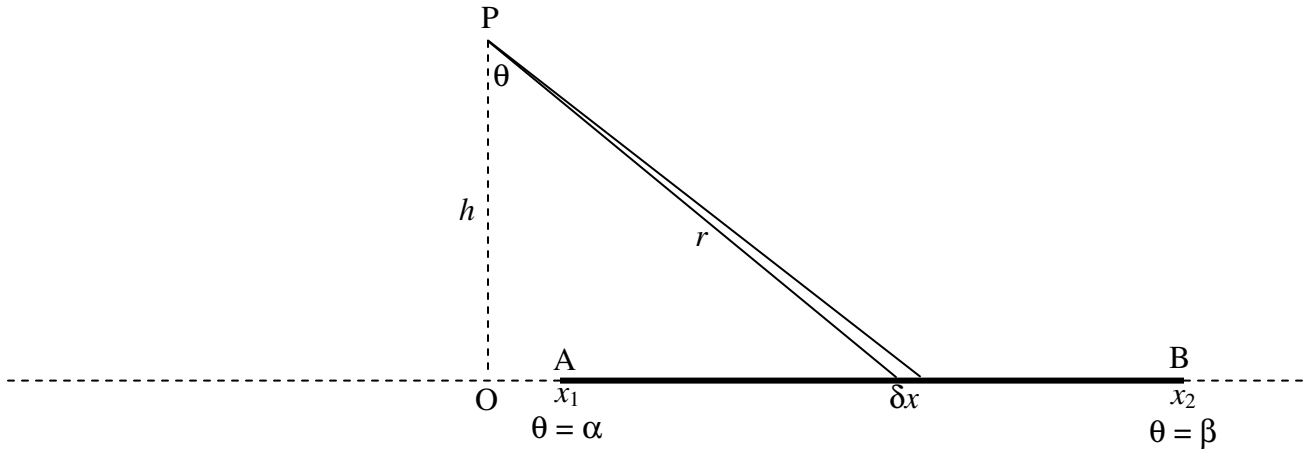
The y -component of the field due to the whole rod is

$$-\frac{G\lambda}{h} \int_{\alpha}^{\beta} \cos \theta d\theta = -\frac{G\lambda}{h} (\sin \beta - \sin \alpha). \quad 5.4.16$$

The total field is the orthogonal sum of these, which, after use of some trigonometric identities (do it!), becomes

$$g = \frac{2G\lambda}{h} \sin \frac{1}{2}(\beta - \alpha) \quad 5.4.17$$

at an angle $\frac{1}{2}(\alpha + \beta)$ - i.e. bisecting the angle APB.

If the rod is of infinite length, we put $\alpha = -\pi/2$ and $\beta = \pi/2$, and we obtain for the field at P

$$g = \frac{2G\lambda}{h}. \quad 5.4.18$$

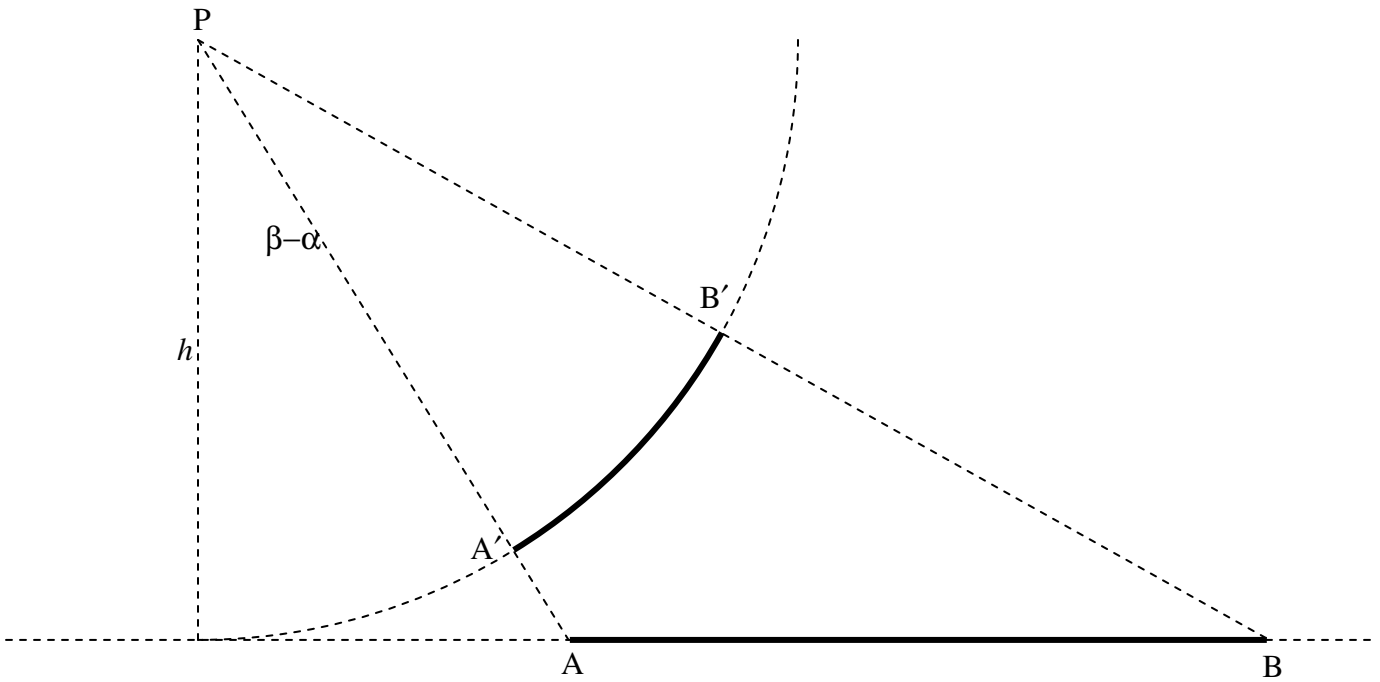
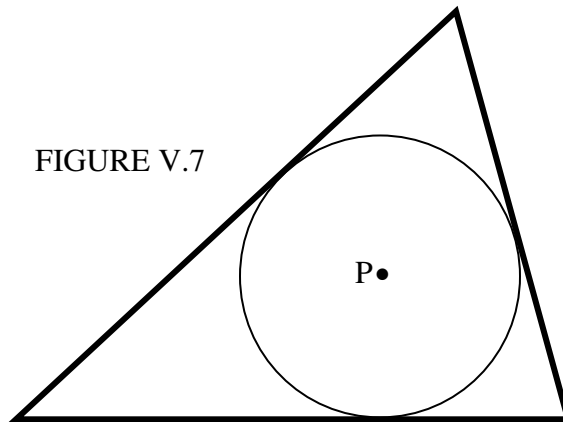

FIGURE V.6

Consider an arc $A'B'$ of a circle of radius h , mass per unit length λ , subtending an angle $\beta - \alpha$ at the centre P of the circle.

Exercise: Show that the field at P is $g = \frac{2G\lambda}{h} \sin \frac{1}{2}(\beta - \alpha)$. This is the same as the field due to the rod AB subtending the same angle. If $A'B'$ is a semicircle, the field at P would be $g = \frac{2G\lambda}{h}$, the same as for an infinite rod.

An interesting result following from this is as follows.



Three massive rods form a triangle. P is the incentre of the triangle (i.e. it is equidistant from all three sides.) The field at P is the same as that which would be obtained if the mass were distributed around the incircle. I.e., it is zero. The same result would hold for any quadrilateral that can be inscribed with a circle – such as a cyclic quadrilateral.

5.4.7 Solid Cylinder.

We do this not because it has any particular relevance to celestial mechanics, but because it is easy to do. We imagine a solid cylinder, density ρ , radius a , length l . We seek to calculate the field at a point P on the axis, at a distance h from one end of the cylinder (figure V.8).

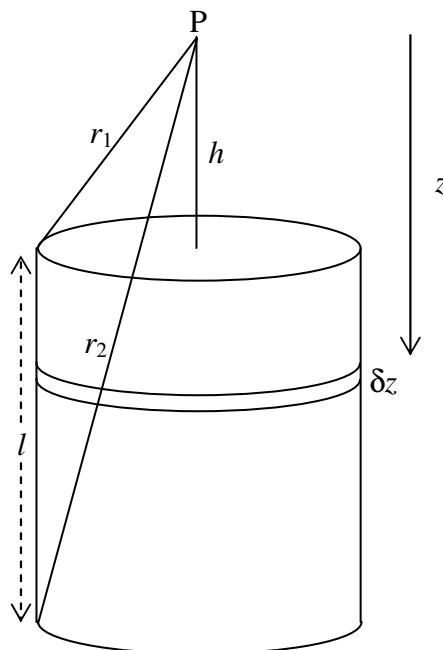

FIGURE V.8

The field at P from an elemental disc of thickness δz a distance z below P is (from equation 5.4.9)

$$\delta g = G\rho \delta z \omega. \quad 5.4.19$$

Here ω is the solid angle subtended at P by the disc, which is $2\pi \left[1 - \frac{z}{(z^2 + a^2)^{1/2}} \right]$. Thus

the field at P from the entire cylinder is

$$g = 2\pi G\rho \int_h^{l+h} \left[1 - \frac{z}{(z^2 + a^2)^{1/2}} \right] dz, \quad 5.4.20$$

or
$$g = 2\pi G\rho \left(l - \sqrt{(l+h)^2 + a^2} + \sqrt{h^2 + a^2} \right), \quad 5.4.21$$

or
$$g = 2\pi G\rho (l - r_2 + r_1). \quad 5.4.22$$

It might also be of interest to express g in terms of the height $y (= \frac{1}{2}l + h)$ of the point P above the mid-point of the cylinder. Instead of equation 5.4.21, we then have

$$g = 2\pi G\rho \left(l - \sqrt{(y + \frac{1}{2}l)^2 + a^2} + \sqrt{(y - \frac{1}{2}l)^2 + a^2} \right). \quad 5.4.23$$

If the point P is *inside* the cylinder, at a distance h below the upper end of the cylinder, the limits of integration in equation 5.4.20 are h and $l - h$, and the distance y is $\frac{1}{2}l - h$. In terms of y the gravitational field at P is then

$$g = 2\pi G\rho \left(2y - \sqrt{(y + \frac{1}{2}l)^2 + a^2} + \sqrt{(y - \frac{1}{2}l)^2 + a^2} \right). \quad 5.4.24$$

In the graph below I have assumed, by way of example, that l and a are both 1, and I have plotted g in units of $2\pi G\rho$ (counting g as positive when it is directed downwards) from $y = -1$ to $y = +1$. The portion inside the cylinder ($-\frac{1}{2} \leq y \leq \frac{1}{2}$), represented by equation 5.4.24, is almost, but not quite, linear. The field at the centre of the cylinder is, of course, zero.

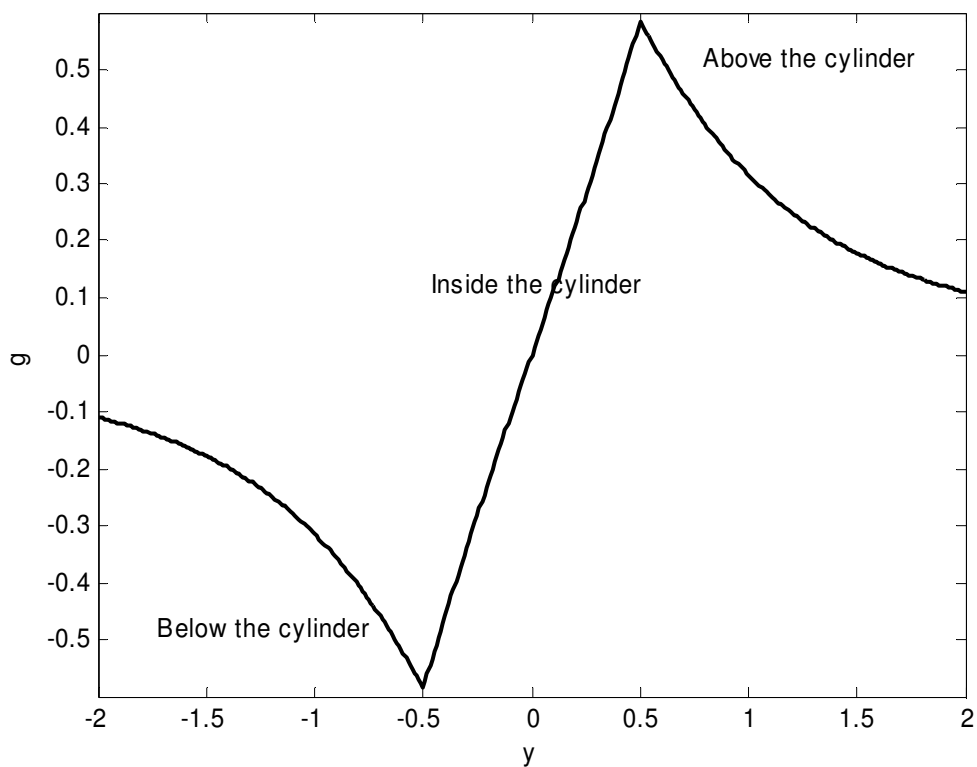

Below, I draw the same graph, but for a thin disc, with $a = 1$ and $l = 0.1$. We see how it is that the field reaches a maximum immediately above or below the disc, but is zero at the centre of the disc.

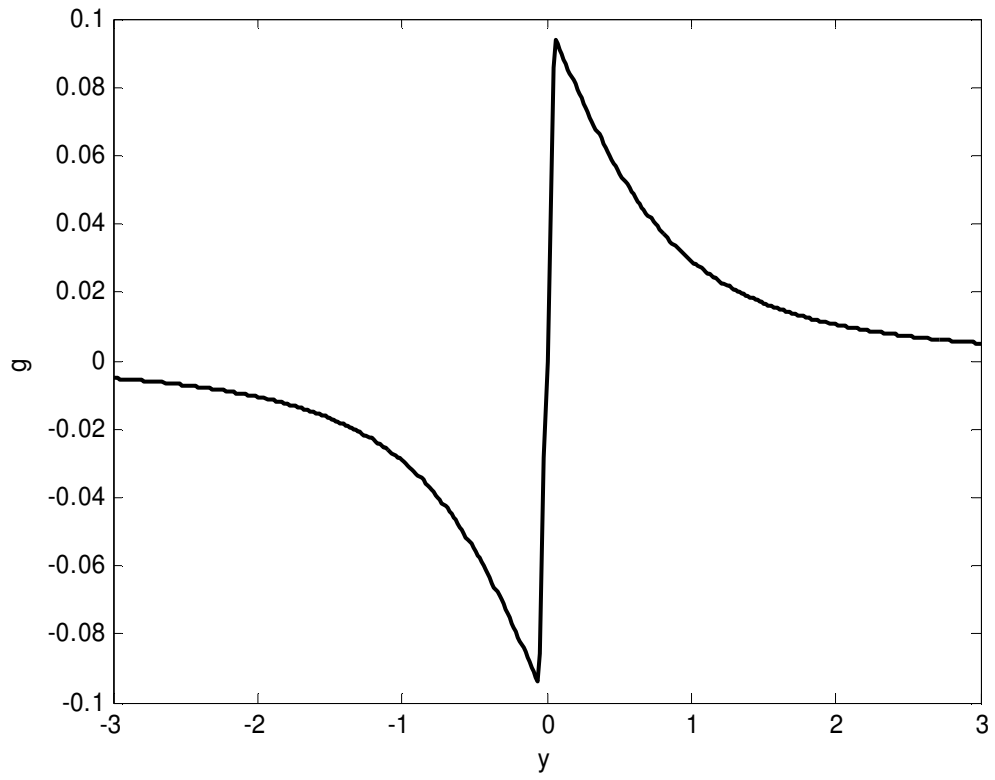

5.4.8 Hollow Spherical Shell.

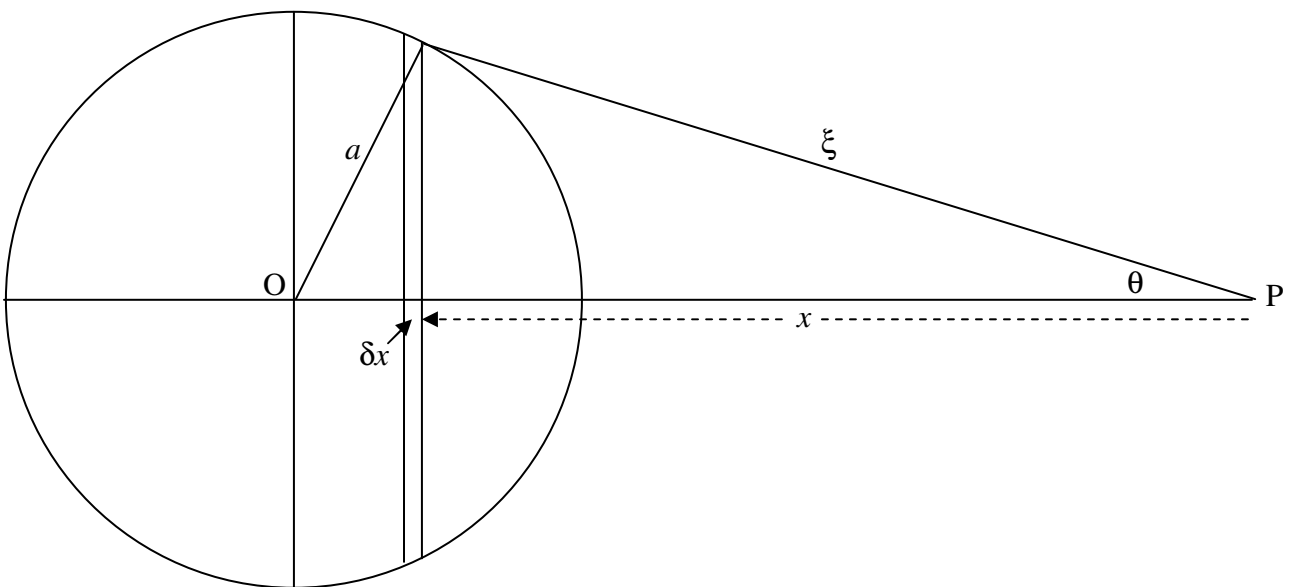

FIGURE V.9

We imagine a hollow spherical shell of radius a , surface density σ , and a point P at a distance r from the centre of the sphere. Consider an elemental zone of thickness δx . The mass of this element is $2\pi a\sigma \delta x$. (In case you doubt this, or you didn't know, "the area of a zone on the surface of a sphere is equal to the corresponding area projected on to the circumscribing cylinder".) The field due to this zone, in the direction PO is

$$\frac{2\pi a\sigma G \cos \theta \delta x}{\xi^2}.$$

Let's express this all in terms of a single variable, ξ . We are going to have to express x and θ in terms of ξ .

We have $a^2 = r^2 + \xi^2 - 2r\xi \cos \theta = r^2 + \xi^2 - 2rx$, from which

$$\cos \theta = \frac{r^2 - a^2 + \xi^2}{2r\xi} \quad \text{and} \quad \delta x = \frac{\xi \delta \xi}{r}.$$

Therefore the field at P due to the zone is $\frac{\pi a G \sigma}{r^2} \left(1 + \frac{r^2 - a^2}{\xi^2} \right) \delta \xi$.

If P is an *external* point, in order to find the field due to the entire spherical shell, we integrate from $\xi = r - a$ to $r + a$. This results in

$$g = \frac{GM}{r^2}. \tag{5.4.23}$$

But if P is an *internal* point, in order to find the field due to the entire spherical shell, we integrate from $\xi = a - r$ to $a + r$, which results in $g = 0$.

Thus we have the important result that the field at an external point due to a hollow spherical shell is exactly the same as if all the mass were concentrated at a point at the centre of the sphere, whereas the field inside the sphere is zero.

Caution. The field inside the sphere is zero only if there are no other masses present. The hollow sphere will not shield you from the gravitational field of any other masses that might be present. Thus in figure V.10, the field at P is the sum of the field due to the hollow sphere (which is indeed zero) and the field of the mass M , which is not zero. Anti-grav is a useful device in science fiction, but does not occur in science fact.

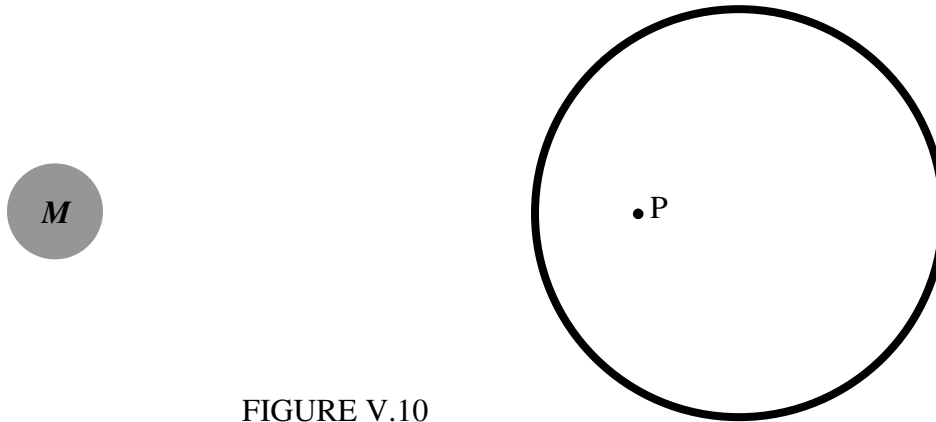

FIGURE V.10

5.4.9 Solid Sphere.

A solid sphere is just lots of hollow spheres nested together. Therefore, the field at an external point is just the same as if all the mass were concentrated at the centre, and the field at an internal point P is the same as if all the mass *interior to* P , namely M_r , were concentrated at the centre, the mass *exterior to* P not contributing at all to the field at P . This is true not only for a sphere of uniform density, but of any sphere in which the density depends only of the distance from the centre – i.e., any spherically symmetric distribution of matter.

If the sphere is uniform, we have $\frac{M_r}{M} = \frac{r^3}{a^3}$, so the field inside is

$$g = \frac{GM_r}{r^2} = \frac{GMr}{a^3}. \quad 5.4.24$$

Thus, inside a uniform solid sphere, the field increases linearly from zero at the centre to GM/a^2 at the surface, and thereafter it falls off as GM/r^2 .

If a uniform hollow sphere has a narrow hole bored through it, and a small particle of mass m is allowed to drop through the hole, the particle will experience a force towards the centre of $GMmr/a^3$, and will consequently oscillate with period P given by

$$P^2 = \frac{4\pi^2}{GM} a^3. \quad 5.4.25$$

5.4.10 *Bubble Inside a Uniform Solid Sphere.*

FIGURE V.11

P is a point inside the bubble. The field at P is equal to the field due to the entire sphere minus the field due to the missing mass of the bubble. That is, it is

$$\mathbf{g} = -\frac{4}{3}\pi G\rho\mathbf{r}_1 - (-\frac{4}{3}\pi G\rho\mathbf{r}_2) = -\frac{4}{3}\pi G\rho(\mathbf{r}_1 - \mathbf{r}_2) = -\frac{4}{3}\pi G\rho\mathbf{c}. \quad 5.4.26$$

That is, the field at P is uniform (i.e. is independent of the position of P) and is parallel to the line joining the centres of the two spheres.

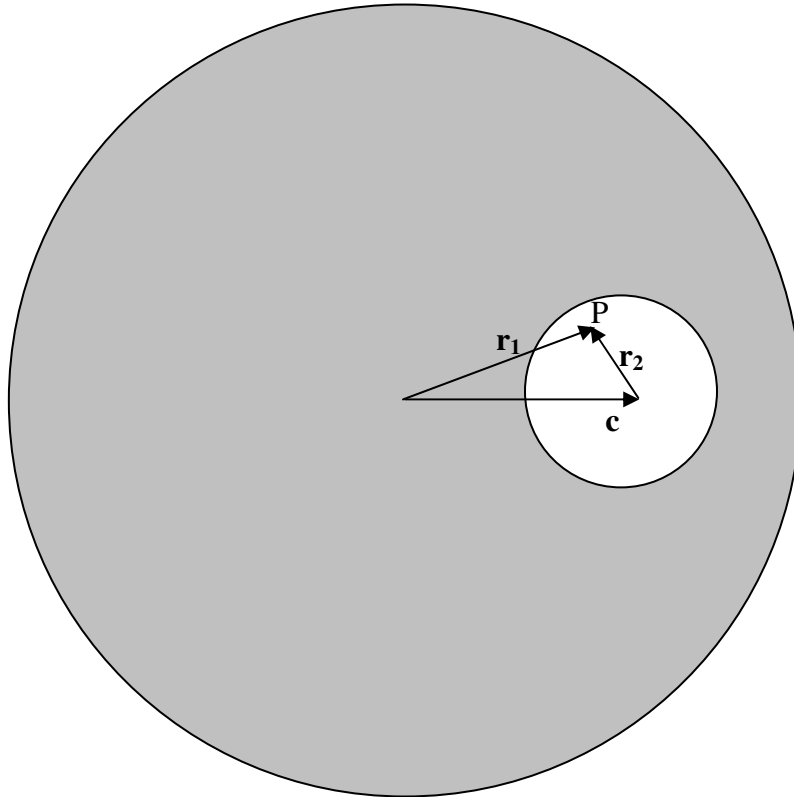
5.5 Gauss's Theorem.

Much of the above may have been good integration practice, but we shall now see that many of the results are immediately obvious from Gauss's Theorem – itself a trivially obvious law. (Or shall we say that, like many things, it is trivially obvious *in hindsight*, though it needed Carl Friedrich Gauss to point it out!)

First let us define gravitational *flux* Φ as an extensive quantity, being the product of gravitational field and area:

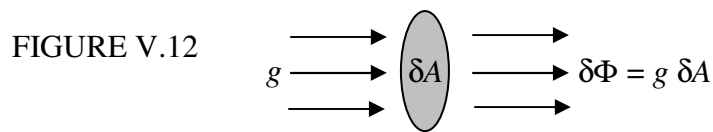

If \mathbf{g} and $\delta\mathbf{A}$ are not parallel, the flux is a scalar quantity, being the scalar or dot product of \mathbf{g} and $\delta\mathbf{A}$:

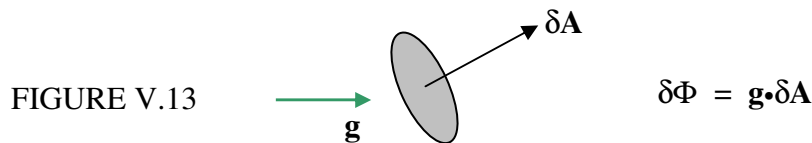

If the gravitational field is threading through a large finite area, we have to calculate $\mathbf{g}\cdot\delta\mathbf{A}$ for each element of area of the surface, the magnitude and direction of \mathbf{g} possibly varying from point to point over the surface, and then we have to integrate this all over the surface. In other words, we have to calculate a *surface integral*. We'll give some examples as we proceed, but first let's move toward Gauss's theorem.

In figure V.14, I have drawn a mass M and several of the gravitational field lines converging on it. I have also drawn a sphere of radius r around the mass. At a distance r from the mass, the field is GM/r^2 . The surface area of the sphere is $4\pi r^2$. Therefore the total inward flux, the product of these two terms, is $4\pi GM$, and is independent of the size of the sphere. (It is independent of the size of the sphere because the field falls off inversely as the square of the distance. Thus Gauss's theorem is a theorem that applies to inverse square fields.) Nothing changes if the mass is not at the centre of the sphere. Nor does it change if (figure V.15) the surface is not a sphere. If there were several

masses inside the surface, each would contribute $4\pi G$ times its mass to the total normal inwards flux. Thus the total normal inward flux through any closed surface is equal to $4\pi G$ times the total mass enclosed by the surface. Or, expressed another way:

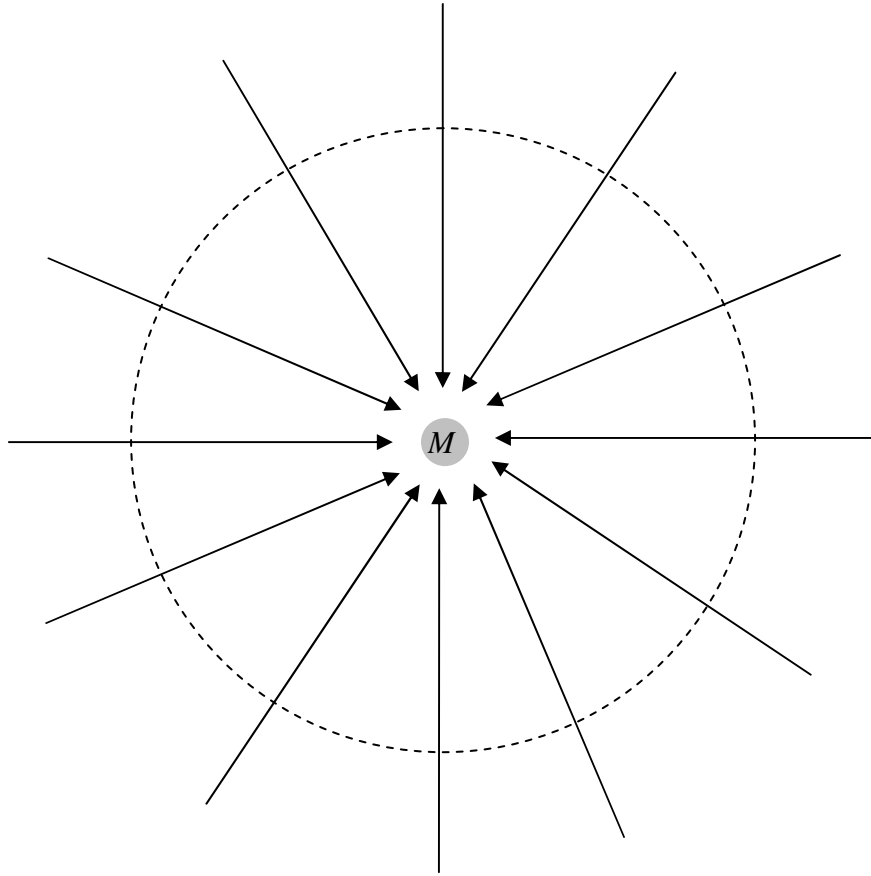

FIGURE V.14

The total normal outward gravitational flux through a closed surface is equal to $-4\pi G$ times the total mass enclosed by the surface.

This is Gauss's theorem.

Mathematically, the flux through the surface is expressed by the surface integral $\iint \mathbf{g} \cdot d\mathbf{A}$. If there is a continuous distribution of matter inside the surface, of density ρ which varies from point to point and is a function of the coordinates, the total mass inside the surface is expressed by $\iiint \rho dV$. Thus Gauss's theorem is expressed mathematically by

$$\iint \mathbf{g} \cdot d\mathbf{A} = -4\pi G \iiint \rho dV. \quad 5.5.1$$

You should check the dimensions of this equation.

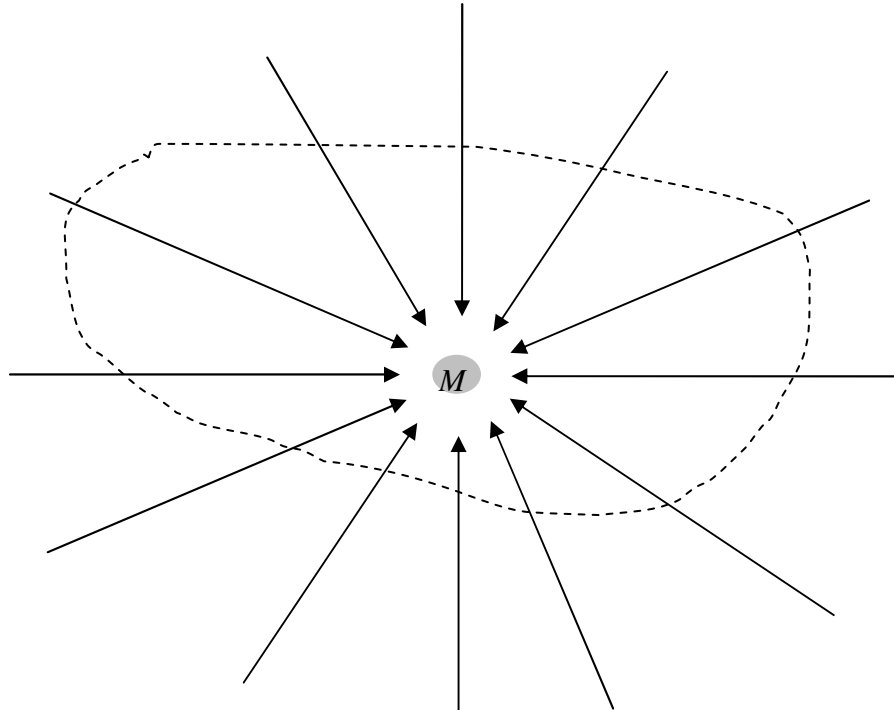

FIGURE V.15

In figure V.16 I have drawn gaussian spherical surfaces of radius r outside and inside hollow and solid spheres. In a and c , the outward flux through the surface is just $-4\pi G$ times the enclosed mass M ; the surface area of the gaussian surface is $4\pi r^2$. This the outward field at the gaussian surface (i.e. at a distance r from the centre of the sphere is $-GM/r^2$. In b , no mass is inside the gaussian surface, and therefore the field is zero. In d , the mass inside the gaussian surface is M_r , and so the outward field is $-GM_r/r^2$.

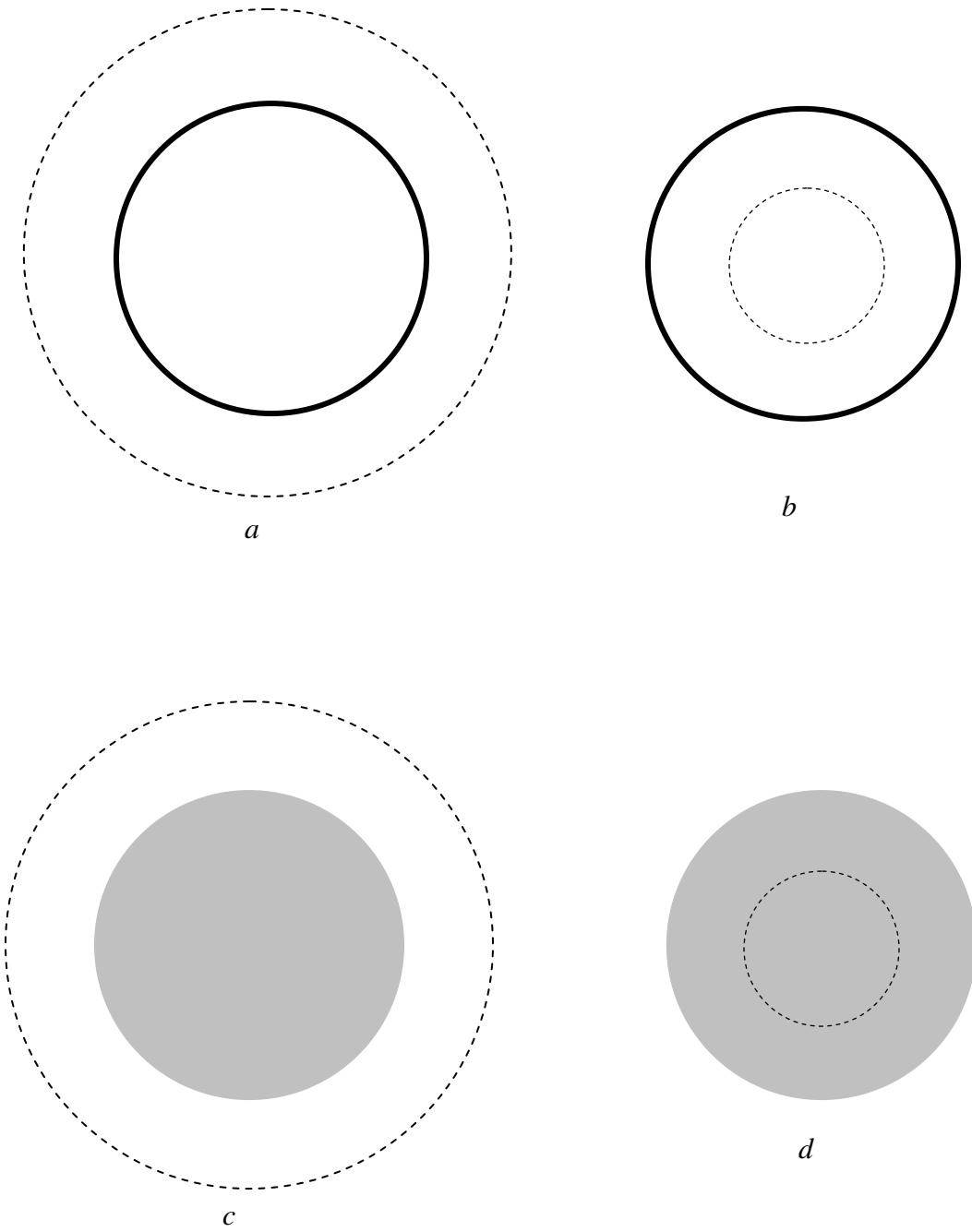

FIGURE V.16

In figure V.17 I draw (part of an) infinite rod of mass λ per unit length, and a cylindrical gaussian surface of radius h and length l around it.

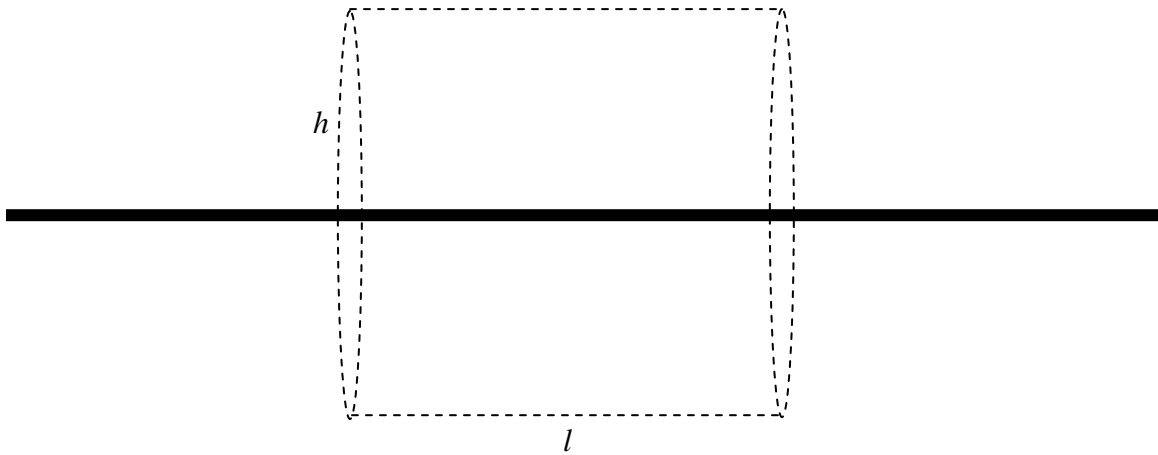

FIGURE V.17

The surface area of the curved surface of the cylinder is $2\pi hl$, and the mass enclosed within it is λl . Thus the outward field at the surface of the gaussian cylinder (i.e. at a distance h from the rod) is $-4\pi G \times \lambda l \div 2\pi hl = -2G\lambda/h$, in agreement with equation 5.4.18.

In figure V.18 I have drawn (part of) an infinite plane lamina of surface density σ , and a cylindrical gaussian surface of cross-sectional area A and height $2h$.

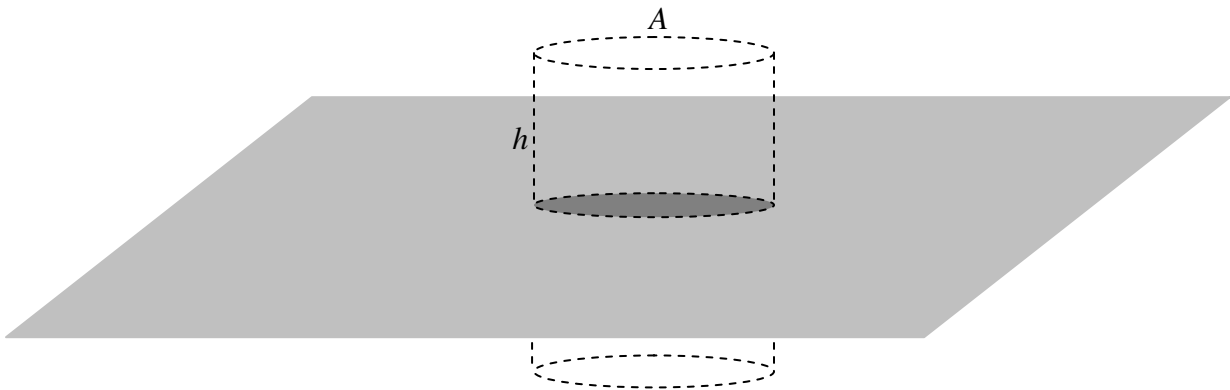

FIGURE V.18

The mass enclosed by the cylinder is σA and the area of the two ends of the cylinder is $2A$. The outward field at the ends of the cylinder (i.e. at a distance h from the plane lamina) is therefore $-4\pi G \times \sigma A \div 2A = -2\pi G\sigma$, in agreement with equation 5.4.13.

5.6 Calculating Surface Integrals.

While the concept of a surface integral sounds easy enough, how do we actually calculate one in practice? In this section I do two examples.

Example 1.

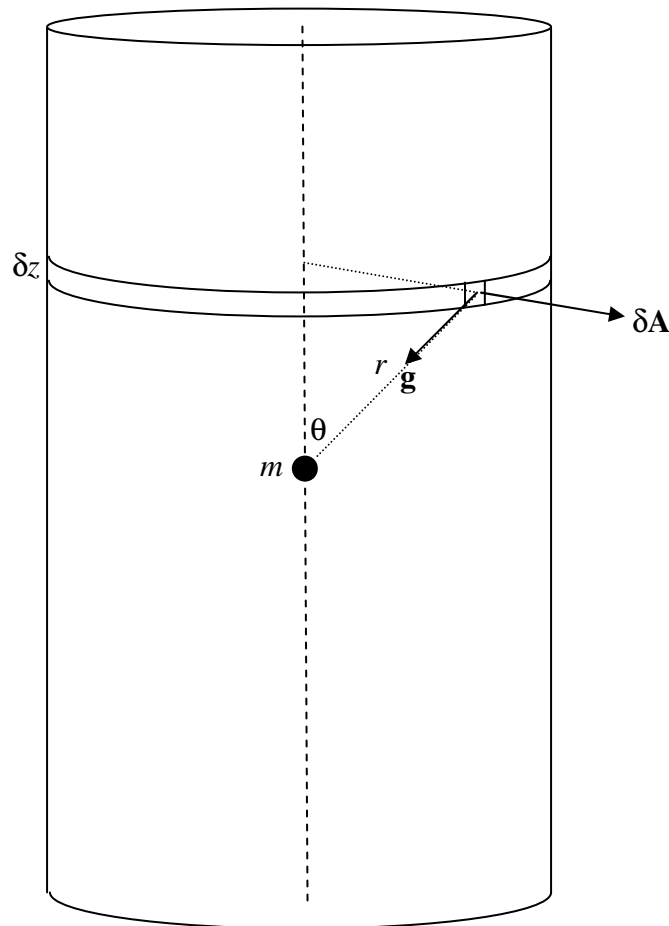

FIGURE V.19

In figure V.19 I show a small mass m , and I have surrounded it with a cylinder of radius a and height $2h$. The problem is to calculate the surface integral $\int \mathbf{g} \cdot d\mathbf{A}$ through the entire

surface of the cylinder. Of course we already know, from Gauss's theorem, that the answer is $= -4\pi Gm$, but we would like to see a surface integral actually carried out.

I have drawn a small element of the surface. Its area δA is dz times $a\delta\phi$, where ϕ is the usual azimuthal angle of cylindrical coordinates. That is, $\delta A = a \delta z \delta\phi$. The magnitude g of the field there is Gm/r^2 , and the angle between \mathbf{g} and $d\mathbf{A}$ is $90^\circ + \theta$. The outward flux through the small element is $\mathbf{g} \cdot \delta\mathbf{A} = \frac{Gma \cos(\theta + 90^\circ) \delta z \delta\phi}{r^2}$. (This is negative – i.e. it is actually an inward flux – because $\cos(\theta + 90^\circ) = -\sin \theta$.) When integrated around the elemental strip δz , this is $-\frac{2\pi Gma \sin \theta \delta z}{r^2}$. To find the flux over the total curved surface, let's integrate this from $z = 0$ to h and double it, or, easier, from $\theta = \pi/2$ to α and double it, where $\tan \alpha = a/h$. We'll need to express z and r in terms of θ (that's easy:– $z = a \cot \theta$ and $r = a \csc \theta$), and the integral becomes

$$4\pi Gm \int_{\pi/2}^{\alpha} \sin \theta d\theta = -4\pi Gm \cos \alpha. \quad 5.6.1$$

Let us now find the flux through one of the flat ends of the cylinder.

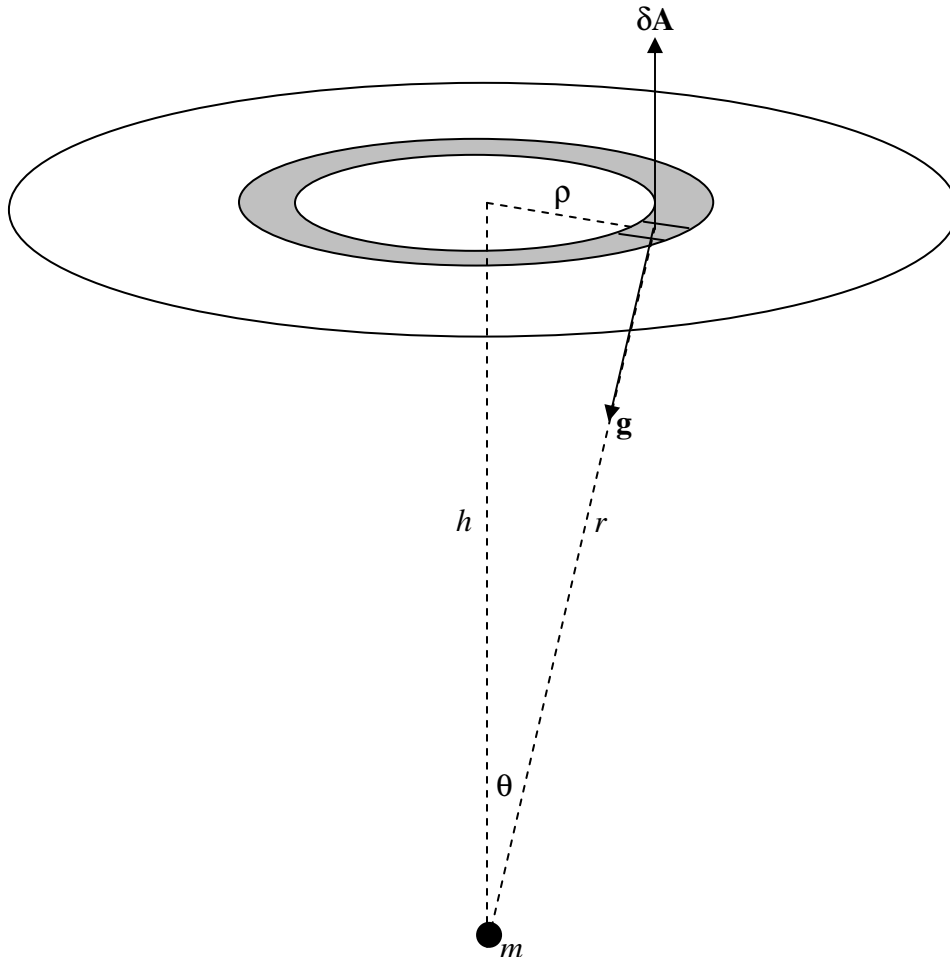

FIGURE V.20

This time, $\delta A = \rho \delta\rho \delta\phi$, $g = Gm/r^2$ and the angle between \mathbf{g} and $\delta\mathbf{A}$ is $180^\circ - \theta$. The outwards flux through the small element is $\frac{Gm\rho \cos(180^\circ - \theta)\delta\rho \delta\phi}{r^2}$ and when integrated around the annulus this becomes $-\frac{2\pi Gm \cos\theta \rho \delta\rho}{r^2}$. We now have to integrate this from $\rho = 0$ to a , or, better, from $\theta = 0$ to α . We have $r = h \sec \theta$ and $\rho = h \tan \theta$, and the integral becomes

$$-2\pi Gm \int_0^\alpha \sin \theta d\theta = -2\pi Gm(1 - \cos \alpha). \quad 5.6.2$$

There are two ends, so the total flux through the entire cylinder is twice this plus equation 5.6.1 to give

$$\Phi = -4\pi Gm, \quad 5.6.3$$

as expected from Gauss's theorem.

Example 2.

FIGURE V.21

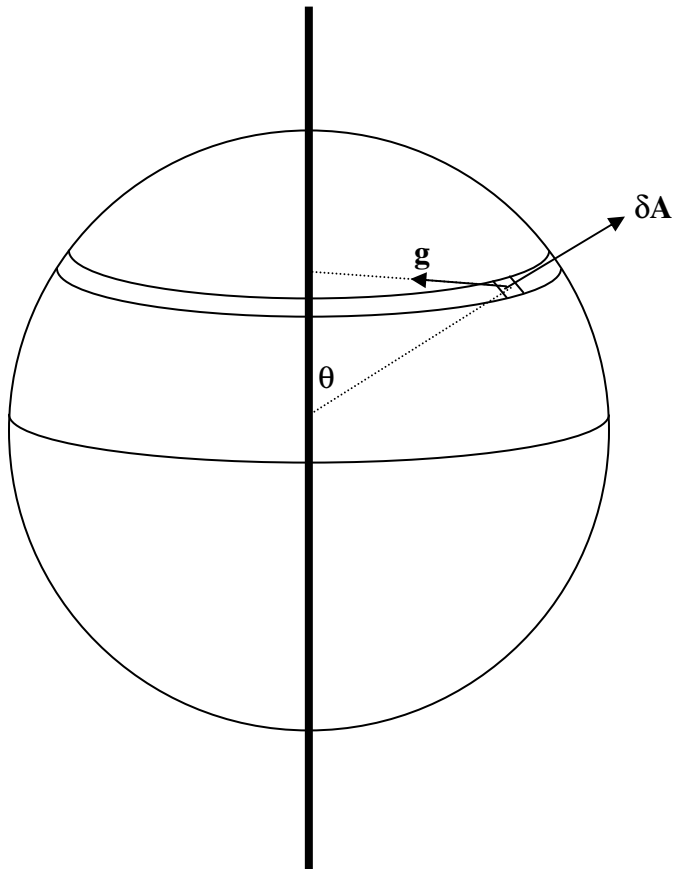

In figure V.21 I have drawn (part of) an infinite rod whose mass per unit length is λ . I have drawn around it a sphere of radius a . The problem will be to determine the total normal flux through the sphere. From Gauss's theorem, we know that the answer must be $-8\pi G a \lambda$. The vector $\delta\mathbf{A}$ representing the element of area is directed away from the centre of the sphere, and the vector \mathbf{g} is directed towards the nearest point of the rod. The angle between them is $\theta + 90^\circ$. The magnitude of $\delta\mathbf{A}$ in spherical coordinates is $a^2 \sin \theta \delta\theta \delta\phi$, and the magnitude of \mathbf{g} is (see equation 5.4.15) $\frac{2G\lambda}{a \sin \theta}$. The dot product $\mathbf{g} \cdot \delta\mathbf{A}$ is

$$\frac{2G\lambda}{a \sin \theta} \cdot a^2 \sin \theta \delta\theta \delta\phi \cdot \cos(\theta + 90^\circ) = -2G\lambda a \sin \theta \delta\theta \delta\phi. \quad 5.6.4$$

To find the total flux, this must be integrated from $\phi = 0$ to 2π and from $\theta = 0$ to π . The result, as expected, is $-8\pi G a \lambda$.

5.7 Potential.

If work is required to move a mass from point A to point B, there is said to be a gravitational *potential difference* between A and B, with B being at the higher potential. The work required to move unit mass from A to B is called the *potential difference* between A and B. In SI units it is expressed in J kg^{-1} .

We have defined only the potential *difference* between *two points*. If we wish to define *the potential* at *a point*, it is necessary arbitrarily to define the potential at a particular point to be zero. We might, for example define the potential at floor level to be zero, in which case the potential at a height h above the floor is gh ; equally we may elect to define the potential at the level of the laboratory bench top to be zero, in which case the potential at a height z above the bench top is gz . Because the value of the potential at a point depends on where we define the zero of potential, one often sees that the potential at some point is equal to some mathematical expression *plus an arbitrary constant*. The value of the constant will be determined once we have decided where we wish to define zero potential.

In celestial mechanics it is usual to assign zero potential to all points *at an infinite distance* from any bodies of interest.

Suppose we decide to define the potential at point A to be zero, and that the potential at B is then $\psi \text{ J kg}^{-1}$. If we move a point mass m from A to B, we shall have to do an amount of work equal to $m\psi \text{ J}$. The *potential energy* of the mass m when it is at B is then $m\psi$. In these notes, I shall usually use the symbol ψ for the potential at a point, and the symbol V for the potential energy of a mass at a point.

In moving a point mass from A to B, it does not matter what *route* is taken. All that matters is the potential difference between A and B. Forces that have the property that the work required to move from one point to another is route-independent are called *conservative forces*; gravitational forces are conservative. The potential at a point is a *scalar* quantity; it has no particular direction associated with it.

If it requires work to move a body from point A to point B (i.e. if there is a potential difference between A and B, and B is at a higher potential than A), this implies that there must be a gravitational field directed from B to A.

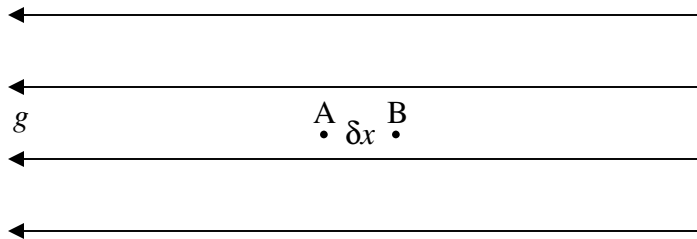

FIGURE V.22

Figure V.22 shows two points, A and B, a distance δx apart, in a region of space where the gravitational field is g directed in the *negative* x direction. We'll suppose that the potential difference between A and B is $\delta\psi$. By definition, the work required to move unit mass from A to B is $\delta\psi$. Also by definition, the force on unit mass is g , so that the work done on unit mass is $g\delta x$. Thus we have

$$g = -\frac{d\psi}{dx}. \quad 5.7.1$$

The minus sign indicates that, while the potential increases from left to right, the gravitational field is directed to the left. In words, the gravitational field is minus the potential gradient.

This was a one-dimensional example. In a later section, when we discuss the vector operator ∇ , we shall write equation 5.7.1 in its three-dimensional form

$$\mathbf{g} = -\mathbf{grad}\psi = -\nabla\psi. \quad 5.7.2$$

While ψ itself is a scalar quantity, having no directional properties, its *gradient* is, of course, a vector.

5.8 The Gravitational Potentials Near Various Bodies.

Because potential is a scalar rather than a vector, potentials are usually easier to calculate than field strengths. Indeed, in order to calculate the gravitational field, it is sometimes easier first to calculate the potential and then to calculate the gradient of the potential.

5.8.1 Potential Near a Point Mass.

We shall define the potential to be zero at infinity. If we are in the vicinity of a point mass, we shall always have to *do work* in moving a test particle *away from* the mass. We shan't reach zero potential until we are an infinite distance away. It follows that the potential at any finite distance from a point mass is *negative*. The potential at a point is the work required to move unit mass *from infinity to the point*; i.e., it is negative.

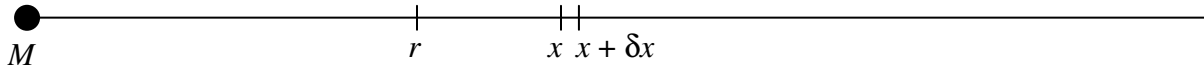

FIGURE V.23

The magnitude of the field at a distance x from a point mass M (figure V.23) is GM/x^2 , and the force on a mass m placed there would be GMm/x^2 . The work required to move m from x to $x + \delta x$ is $GMm\delta x/x^2$. The work required to move it from r to infinity is $GMm \int_r^\infty \frac{dx}{x^2} = \frac{GMm}{r}$. The work required to move *unit* mass *from* ∞ *to* r , which is the potential at r is

$$\psi = -\frac{GM}{r}. \quad 5.8.1$$

The *mutual potential energy* of two point masses a distance r apart, which is the work required to bring them to a distance r from an infinite initial separation, is

$$V = -\frac{GMm}{r}. \quad 5.8.2$$

I here summarize a number of similar-looking formulas, although there is, of course, not the slightest possibility of confusing them. Here goes:

Force between two masses:

$$F = \frac{GMm}{r^2}. \quad \text{N} \quad 5.8.3$$

Field near a point mass:

$$g = \frac{GM}{r^2}, \quad \text{N kg}^{-1} \text{ or } \text{m s}^{-2} \quad 5.8.4$$

which can be written in vector form as:

$$\mathbf{g} = -\frac{GM}{r^2} \hat{\mathbf{r}} \quad \text{N kg}^{-1} \text{ or } \text{m s}^{-2} \quad 5.8.5$$

or as:

$$\mathbf{g} = -\frac{GM}{r^3} \mathbf{r}. \quad \text{N kg}^{-1} \text{ or } \text{m s}^{-2} \quad 5.8.6$$

Mutual potential energy of two masses:

$$V = -\frac{GMm}{r}. \quad \text{J} \quad 5.8.7$$

Potential near a point mass:

$$\psi = -\frac{GM}{r}. \quad \text{J kg}^{-1} \quad 5.8.8$$

I hope that's crystal clear.

5.8.2 Potential on the Axis of a Ring.

We can refer to figure V.1. The potential at P from the element δM is $-\frac{G\delta M}{(a^2 + z^2)^{1/2}}$. This is the same for all such elements around the circumference of the ring, and the total potential is just the scalar sum of the contributions from all the elements. Therefore the total potential on the axis of the ring is:

$$\psi = -\frac{GM}{(a^2 + z^2)^{1/2}}. \quad 5.8.9$$

The z -component of the field (its only component) is $-d/dz$ of this, which results in $g = -\frac{GMz}{(a^2 + z^2)^{3/2}}$. This is the same as equation 5.4.1 except for sign. When we derived equation 5.4.1 we were concerned only with the magnitude of the field. Here $-d\psi/dz$ gives the z -component of the field, and the minus sign correctly indicates that the field is directed in the negative z -direction. Indeed, since potential, being a scalar quantity, is easier to work out than field, the easiest way to calculate a field is first to calculate the potential and then differentiate it. On the other hand, sometimes it is easy to calculate a field from Gauss's theorem, and then calculate the potential by integration. It is nice to have so many easy ways of doing physics!

5.8.3 Plane Discs.

Refer to figure V.2A. The potential at P from the elemental disc is

$$d\psi = -\frac{G\delta M}{(r^2 + z^2)^{1/2}} = -\frac{2\pi G \sigma r \delta r}{(r^2 + z^2)^{1/2}}. \quad 5.8.10$$

The potential from the whole disc is therefore

$$\psi = -2\pi G\sigma \int_0^a \frac{r dr}{(r^2 + z^2)^{1/2}}. \quad 5.8.11$$

The integral is trivial after a brilliant substitution such as $X = r^2 + z^2$ or $r = z \tan \theta$, and we arrive at

$$\psi = -2\pi G\sigma (\sqrt{z^2 + a^2} - z). \quad 5.8.12$$

This increases to zero as $z \rightarrow \infty$. We can also write this as

$$\psi = -\frac{2\pi Gm}{\pi a^2} \left[z \left(1 + \frac{a^2}{z^2} \right)^{1/2} - z \right], \quad 5.8.13$$

and, if you expand this binomially, you see that for large z it becomes, as expected, $-Gm/z^2$.

5.8.4 Infinite Plane Lamina.

The field above an infinite uniform plane lamina of surface density σ is $-2\pi G\sigma$. Let A be a point at a distance a from the lamina and B be a point at a distance b from the lamina (with $b > a$), the potential difference between B and A is

$$\psi_B - \psi_A = 2\pi G\sigma(b-a). \quad 5.8.14$$

If we elect to call the potential zero *at the surface* of the lamina, then, at a distance h from the lamina, the potential will be $+2\pi G\sigma h$.

5.8.5 Hollow Hemisphere.

Any element of mass, δM on the surface of a hemisphere of radius a is at a distance a from the centre of the hemisphere, and therefore the potential due to this element is merely $-G\delta M/a$. Since potential is a scalar quantity, the potential of the entire hemisphere is just $-GM/a$.

5.8.6 Rods.

Refer to figure V.5. The potential at P due to the element δx is $-\frac{G\lambda\delta x}{r} = -G\lambda\sec\theta\delta\theta$. The total potential at P is therefore

$$\psi = -G\lambda\int_{\alpha}^{\beta}\sec\theta d\theta = -G\lambda\ln\left[\frac{\sec\beta + \tan\beta}{\sec\alpha + \tan\alpha}\right]. \quad 5.8.15$$

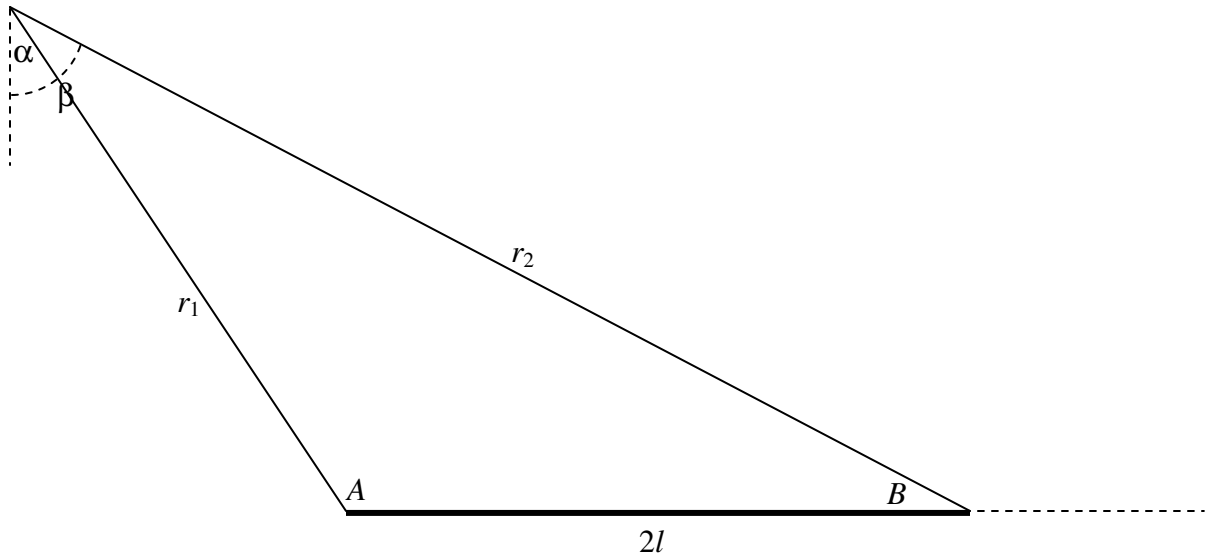

FIGURE V.24

Refer now to figure V.24, in which $A = 90^\circ + \alpha$ and $B = 90^\circ - \beta$.

$$\begin{aligned} \frac{\sec \beta + \tan \beta}{\sec \alpha + \tan \alpha} &= \frac{\cos \alpha(1 + \sin \beta)}{\cos \beta(1 + \sin \alpha)} = \frac{\sin A(1 + \cos B)}{\sin B(1 - \cos A)} = \frac{2 \sin \frac{1}{2}A \cos \frac{1}{2}A \cdot 2 \cos^2 \frac{1}{2}B}{2 \sin \frac{1}{2}B \cos \frac{1}{2}B \cdot 2 \sin^2 \frac{1}{2}A} \\ &= \cot \frac{1}{2}A \cot \frac{1}{2}B = \sqrt{\frac{s(s-r_2)}{(s-r_1)(s-2l)}} \cdot \sqrt{\frac{s(s-r_1)}{(s-2l)(s-r_2)}}, \end{aligned}$$

where $s = \frac{1}{2}(r_1 + r_2 + 2l)$. (You may want to refer here to the formulas on pp. 37 and 38 of Chapter 2.)

$$\text{Hence} \quad \psi = -G\lambda \ln \left[\frac{r_1 + r_2 + 2l}{r_1 + r_2 - 2l} \right]. \quad 5.8.16$$

If r_1 and r_2 are very large compared with l , they are nearly equal, so let's put $r_1 + r_2 = 2r$ and write equation 5.8.17 as

$$\psi = -\frac{Gm}{2l} \ln \left[\frac{2r \left(1 + \frac{2l}{2r}\right)}{2r \left(1 - \frac{2l}{2r}\right)} \right] = -\frac{Gm}{2l} \left[\ln \left(1 + \frac{l}{r}\right) - \ln \left(1 - \frac{l}{r}\right) \right].$$

Maclaurin expand the logarithms, and you will see that, at large distances from the rod, the potential is, expected, $-Gm/r$.

Let us return to the near vicinity of the rod and to equation 5.8.16. We see that if we move around the rod in such a manner that we keep $r_1 + r_2$ constant and equal to $2a$, say – that is to say if we move around the rod in an *ellipse* (see our definition of an ellipse in Chapter 2, Section 2.3) – the potential is constant. In other words the equipotentials are confocal ellipses, with the foci at the ends of the rod. Equation 5.8.16 can be written

$$\psi = -G\lambda \ln \left(\frac{a+l}{a-l} \right). \quad 5.8.17$$

For a given potential ψ , the equipotential is an ellipse of major axis

$$2a = 2l \left(\frac{e^{\psi/(G\lambda)} + 1}{e^{\psi/(G\lambda)} - 1} \right), \quad 5.8.20$$

where $2l$ is the length of the rod. This knowledge is useful if you are exploring space and you encounter an alien spacecraft or an asteroid in the form of a uniform rod of length $2l$.

5.8.7 Solid Cylinder.

Refer to figure V.8. The potential from the elemental disc is

$$d\psi = -2\pi G\rho \delta z \left[(z^2 + a^2)^{1/2} - z \right] \quad 5.8.21$$

and therefore the potential from the entire cylinder is

$$\psi = \text{const.} - 2\pi G\rho \left[\int_h^{h+l} (z^2 + a^2)^{1/2} dz - \int_h^{h+l} z dz \right]. \quad 5.8.22$$

I leave it to the reader to carry out this integration and obtain a final expression. One way to deal with the first integral might be to try $z = a \tan \theta$. This may lead to $\int \sec^3 \theta d\theta$. From there, you could try something like

$$\begin{aligned} \int \sec^3 \theta &= \int \sec \theta d \tan \theta = \sec \theta \tan \theta - \int \tan \theta d \sec \theta = \sec \theta \tan \theta - \int \sec \theta \tan^2 \theta d\theta \\ &= \sec \theta \tan \theta - \int \sec^3 \theta + \int \sec \theta d\theta, \text{ and so on.} \end{aligned}$$

5.8.8 Hollow Spherical Shell.

Outside the sphere, the field and the potential are just as if all the mass were concentrated at a point in the centre. The potential, then, outside the sphere, is just $-GM/r$. *Inside* the sphere, the field is zero and therefore the potential is uniform and is equal to the potential at the surface, which is $-GM/a$. The reader should draw a graph of the potential as a function of distance from centre of the sphere. There is a discontinuity in the slope of the potential (and hence in the field) at the surface.

5.8.9 Solid Sphere.

FIGURE V.24A

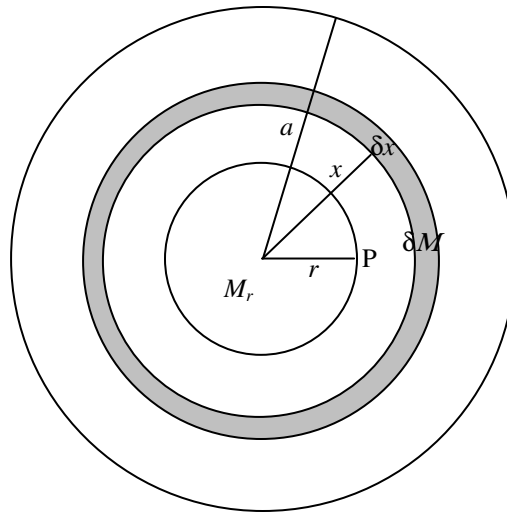

The potential *outside* a solid sphere is just the same as if all the mass were concentrated at a point in the centre. This is so, even if the density is not uniform, and long as it is spherically distributed. We are going to find the potential at a point P inside a uniform sphere of radius a , mass M , density ρ , at a distance r from the centre ($r < a$). We can do this in two parts. First, there is the potential from that part of the sphere “below” P. This is $-GM_r/r$, where $M_r = \frac{r^3 M}{a^3}$ is the mass within radius r . Now we need to deal with the material “above” P. Consider a spherical shell of radii $x, x + \delta x$. Its mass is $\delta M = \frac{4\pi x^2 \delta x}{\frac{4}{3}\pi a^3} \cdot M = \frac{3Mx^2 \delta x}{a^3}$. The potential from this shell is $-G \delta M/x = -\frac{3GMx \delta x}{a^3}$. This is to be integrated from $x = 0$ to a , and we must then add the contribution from the material “below” P. The final result is

$$\psi = -\frac{GM}{2a^3}(3a^2 - r^2). \quad 5.8.23$$

Figure V.25 shows the potential both inside and outside a uniform solid sphere. The potential is in units of $-GM/r$, and distance is in units of a , the radius of the sphere.

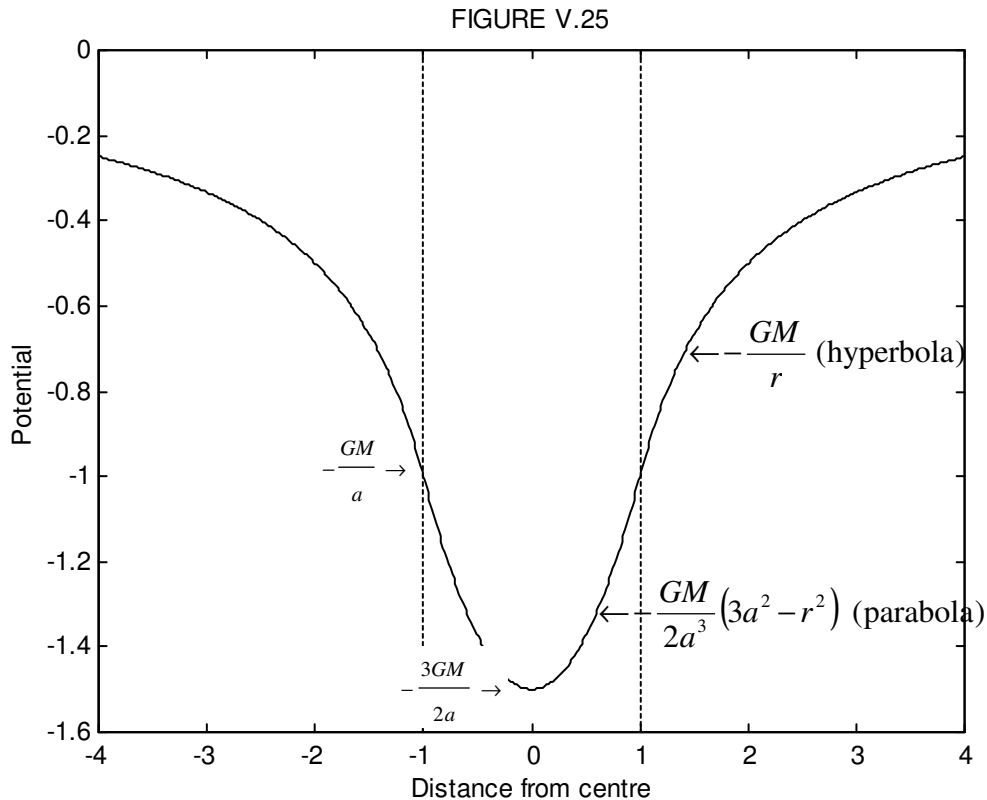

5.9 Work Required to Assemble a Uniform Sphere.

Let us imagine a uniform solid sphere of mass M , density ρ and radius a . In this section we ask ourselves, how much work was done in order to assemble together all the atoms that make up the sphere if the atoms were initially all separated from each other by an infinite distance? Well, since massive bodies (such as atoms) attract each other by gravitational forces, they will naturally eventually congregate together, so in fact you would have to do work in *dis*-assembling the sphere and removing all the atoms to an infinite separation. To bring the atoms together from an infinite separation, the amount of work that you do is *negative*.

Let us suppose that we are part way through the process of building our sphere and that, at present, it is of radius r and of mass $M_r = \frac{4}{3}\pi r^3 \rho$. The potential at its surface is

$$-\frac{GM_r}{r} = -\frac{G}{r} \cdot \frac{4\pi r^3 \rho}{3} = -\frac{4}{3}\pi G r^2.$$

The amount of work required to add a layer of thickness δr and mass $4\pi r^2 \rho \delta r$ to this is

$$-\frac{4}{3}\pi G r^2 \times 4\pi r^2 \rho \delta r = -\frac{16}{3}\pi^2 G \rho^2 r^4 \delta r.$$

The work done in assembling the entire sphere is the integral of this from $r = 0$ to a , which is

$$-\frac{16\pi^2 G \rho^2 a^5}{15} = -\frac{3GM^2}{5a}. \quad 5.9.1$$

5.10 Nabla, Gradient and Divergence.

We are going to meet, in this section, the symbol ∇ . In North America it is generally pronounced “del”, although in the United Kingdom and elsewhere one sometimes hears the alternative pronunciation “nabla”, called after an ancient Assyrian harp-like instrument of approximately that shape.

In section 5.7, particularly equation 5.7.1, we introduced the idea that the gravitational field g is minus the gradient of the potential, and we wrote $g = -d\psi/dx$. This equation refers to an essentially one-dimensional situation. In real life, the gravitational potential is a three dimensional scalar function $\psi(x, y, z)$, which varies from point to point, and its *gradient* is

$$\mathbf{grad} \psi = \mathbf{i} \frac{\partial \psi}{\partial x} + \mathbf{j} \frac{\partial \psi}{\partial y} + \mathbf{k} \frac{\partial \psi}{\partial z}, \quad 5.10.1$$

which is a vector field whose magnitude and direction vary from point to point. The gravitational field, then, is given by

$$\mathbf{g} = -\mathbf{grad} \psi . \quad 5.10.2$$

Here, \mathbf{i} , \mathbf{j} and \mathbf{k} are the unit vectors in the x -, y - and z -directions.

The operator ∇ is $\mathbf{i} \frac{\partial}{\partial x} + \mathbf{j} \frac{\partial}{\partial y} + \mathbf{k} \frac{\partial}{\partial z}$, so that equation 5.10.2 can be written

$$\mathbf{g} = -\nabla\psi . \quad 5.10.3$$

I suppose one could write a long book about ∇ , but I am going to try to restrict myself in this section to some bare essentials.

Let us suppose that we have some vector field, which we might as well suppose to be a gravitational field, so I'll call it \mathbf{g} . (If you don't want to be restricted to a gravitational field, just call the field \mathbf{A} as some sort of undefined or general vector field.) We can calculate the quantity

$$\nabla \cdot \mathbf{g} = \left(\mathbf{i} \frac{\partial}{\partial x} + \mathbf{j} \frac{\partial}{\partial y} + \mathbf{k} \frac{\partial}{\partial z} \right) \cdot \left(\mathbf{i}g_x + \mathbf{j}g_y + \mathbf{k}g_z \right). \quad 5.10.4$$

When this is multiplied out, we obtain a *scalar* field called the *divergence* of \mathbf{g} :

$$\nabla \cdot \mathbf{g} = \text{div } \mathbf{g} = \frac{\partial g_x}{\partial x} + \frac{\partial g_y}{\partial y} + \frac{\partial g_z}{\partial z}. \quad 5.10.5$$

Is this of any use?

Here's an example of a possible useful application. Let us imagine that we have some field \mathbf{g} which varies in magnitude and direction through some volume of space. Each of the components, g_x , g_y , g_z can be written as functions of the coordinates. Now suppose that we want to calculate the surface integral of g through the closed boundary of the volume of space in question. Can you just imagine what a headache that might be? For example, suppose that $\mathbf{g} = x^2\mathbf{i} - xy\mathbf{j} - xz\mathbf{k}$, and I were to ask you to calculate the surface integral over the surface of the ellipsoid $\frac{x^2}{a^2} + \frac{y^2}{b^2} + \frac{z^2}{c^2} = 1$. It would be hard to know where to begin.

Well, there is a theorem, which I am not going to derive here, but which can be found in many books on mathematical physics, and is not particularly difficult, which says:

The surface integral of a vector field over a closed surface is equal to the volume integral of its divergence.

In symbols:
$$\iint \mathbf{g} \cdot d\mathbf{A} = \iiint \text{div } \mathbf{g} dV. \quad 5.10.6$$

If we know g_x , g_y and g_z as functions of the coordinates, then it is often very simple and straightforward to calculate the divergence of \mathbf{g} , which is a scalar function, and it is then often equally straightforward to calculate the volume integral. The example I gave in the previous paragraph is trivially simple (it is a rather artificial example, designed to be ridiculously simple) and you will readily find that $\text{div } \mathbf{g}$ is everywhere zero, and so the surface integral over the ellipsoid is zero.

If we combine this very general theorem with Gauss's theorem (which applies to an inverse square field), which is that the surface integral of the field over a closed volume is equal to $-4\pi G$ times the enclosed mass (equation 5.5.1) we understand immediately that the divergence of \mathbf{g} at any point is related to the density at that point and indeed that

$$\text{div } \mathbf{g} = \nabla \cdot \mathbf{g} = -4\pi G\rho. \quad 5.10.7$$

This may help to give a bit more physical meaning to the divergence. At a point in space where the local density is zero, $\text{div } \mathbf{g}$, of course, is also zero.

Now equation 5.10.2 tells us that $\mathbf{g} = -\nabla\psi$, so that we also have

$$\nabla \cdot (-\nabla\psi) = -\nabla \cdot (\nabla\psi) = -4\pi G\rho. \quad 5.10.8$$

If you write out the expressions for ∇ and for $\nabla\psi$ in full and calculate the dot product, you will find that $\nabla \cdot (\nabla\psi)$, which is also written $\nabla^2\psi$, is $\frac{\partial^2\psi}{\partial x^2} + \frac{\partial^2\psi}{\partial y^2} + \frac{\partial^2\psi}{\partial z^2}$. Thus we obtain

$$\nabla^2\psi = \frac{\partial^2\psi}{\partial x^2} + \frac{\partial^2\psi}{\partial y^2} + \frac{\partial^2\psi}{\partial z^2} = 4\pi G\rho. \quad 5.10.9$$

This is *Poisson's equation*. At any point in space where the local density is zero, it becomes

$$\nabla^2\psi = 0 \quad 5.10.10$$

which is *Laplace's equation*. Thus, no matter how complicated the distribution of mass, the potential as a function of the coordinates must satisfy these equations.

We leave this topic here. Further details are to be found in books on mathematical physics; our aim here was just to obtain some feeling for the physical meaning. I add just a few small comments. One is, yes, it is certainly possible to operate on a vector field with the operator $\nabla \times$. Thus, if \mathbf{A} is a vector field, $\nabla \times \mathbf{A}$ is called the **curl** of \mathbf{A} . The **curl** of a gravitational field is zero, and so there is no need for much discussion of it in a chapter on gravitational fields. If, however, you have occasion to study fluid dynamics or

electromagnetism, you will need to become very familiar with it. I particularly draw your attention to a theorem that says

*The line integral of a vector field around a closed plane circuit is equal to the surface integral of its **curl**.*

This will enable you easily to calculate two-dimensional line integrals in a similar manner to that in which the divergence theorem enables you to calculate three-dimensional surface integrals.

Another comment is that very often calculations are done in spherical rather than rectangular coordinates. The formulas for **grad**, **div**, **curl** and ∇^2 are then rather more complicated than their simple forms in rectangular coordinates.

Finally, there are dozens and dozens of formulas relating to nabla in the books, such as “**curl curl** = **grad** div minus nabla-squared”. While they should certainly never be memorized, they are certainly worth becoming familiar with, even if we do not need them immediately here.

5.11 Legendre Polynomials.

In this section we cover just enough about Legendre polynomials to be useful in the following section. Before starting, I want you to expand the following expression, by the binomial theorem, for $|x| < 1$, up to x^4 :

$$\frac{1}{(1 - 2x \cos \theta + x^2)^{1/2}}. \quad 5.11.1$$

Please do go ahead and do it.

Well, you probably won't, so I'd better do it myself:

I'll start with

$$(1 - X)^{-1/2} = 1 + \frac{1}{2}X + \frac{3}{8}X^2 + \frac{5}{16}X^3 + \frac{35}{128}X^4 \dots \quad 5.11.2$$

and therefore

$$\begin{aligned} [1 - x(2 \cos \theta - x)]^{-1/2} &= 1 + \frac{1}{2}x(2 \cos \theta - x) \\ &+ \frac{3}{8}x^2(2 \cos \theta - x)^2 \\ &+ \frac{5}{16}x^3(2 \cos \theta - x)^3 \\ &+ \frac{35}{128}x^4(2 \cos \theta - x)^4 \dots \end{aligned} \quad 5.11.3$$

$$\begin{aligned}
&= 1 + x \cos \theta - \frac{1}{2} x^2 \\
&\quad + \frac{3}{8} x^2 (4 \cos^2 \theta - 4x \cos \theta + x^2) \\
&\quad + \frac{5}{16} x^3 (8 \cos^3 \theta - 12x \cos^2 \theta + 6x^2 \cos \theta - x^3) \\
&\quad + \frac{35}{128} x (16 \cos^4 \theta - 32x \cos^3 \theta + 24x^2 \cos^2 \theta - 8x^3 \cos \theta + x^4) \dots
\end{aligned} \tag{5.11.4}$$

$$\begin{aligned}
&= 1 + x \cos \theta + x^2 \left(-\frac{1}{2} + \frac{3}{2} \cos^2 \theta \right) + x^3 \left(-\frac{3}{2} \cos \theta + \frac{5}{2} \cos^3 \theta \right) \\
&\quad + x^4 \left(\frac{3}{8} - \frac{15}{4} \cos^2 \theta + \frac{35}{8} \cos^4 \theta \right) \dots
\end{aligned} \tag{5.11.5}$$

The coefficients of the powers of x are the *Legendre polynomials* $P_l(\cos \theta)$, so that

$$\frac{1}{(1-2x \cos \theta + x^2)^{1/2}} = 1 + x P_1(\cos \theta) + x^2 P_2(\cos \theta) + x^3 P_3(\cos \theta) + x^4 P_4(\cos \theta) + \dots \tag{5.11.6}$$

The Legendre polynomials with argument $\cos \theta$ can be written as series of terms in powers of $\cos \theta$ by substitution of $\cos \theta$ for x in equations 1.12.5 in Section 1.12 of Chapter 1. Note that x in Section 1 is not the same as x in the present section. Alternatively they can be written as series of cosines of multiples of θ as follows.

$$\begin{aligned}
P_0 &= 1 \\
P_1 &= \cos \theta \\
P_2 &= \frac{1}{4} (3 \cos 2\theta + 1) \\
P_3 &= \frac{1}{8} (5 \cos 3\theta + 3 \cos \theta) \\
P_4 &= \frac{1}{64} (35 \cos 4\theta + 20 \cos 2\theta + 9) \\
P_5 &= \frac{1}{128} (63 \cos 5\theta + 35 \cos 3\theta + 30 \cos \theta) \\
P_6 &= \frac{1}{512} (231 \cos 6\theta + 126 \cos 4\theta + 105 \cos 2\theta + 50) \\
P_7 &= \frac{1}{1024} (429 \cos 7\theta + 231 \cos 5\theta + 189 \cos 3\theta + 175 \cos \theta) \\
P_8 &= (6435 \cos 8\theta + 3432 \cos 6\theta + 2772 \cos 4\theta + 2520 \cos 2\theta + 1225) / 2^{14}
\end{aligned} \tag{5.11.7}$$

For example, $P_6(\cos \theta)$ can be written either as given by equation 5.11.7, or as given by equation 1, namely

$$P_6 = \frac{1}{16} (231c^6 - 315c^4 + 105c^2 - 5), \quad \text{where } c = \cos \theta. \tag{5.11.8}$$

The former may look neater, and the latter may look “awkward” because of all the powers. However, the latter is far faster to compute, particularly when written as nested parentheses:

$$P_6 = (-5 + C(105 + C(-315 + 231C)))/16, \quad \text{where } C = \cos^2 \theta. \quad 5.11.9$$

5.12 *Gravitational Potential of any Massive Body.*

You might just want to look at **Chapter 2 of Classical Mechanics** (Moments of Inertia) before proceeding further with this chapter.

In figure VIII.26 I draw a massive body whose centre of mass is C , and an external point P at a distance R from C . I draw a set of $Cxyz$ axes, such that P is on the z -axis, the coordinates of P being $(0, 0, z)$. I indicate an element δm of mass, distant r from C and l from P . I'll suppose that the density at δm is ρ and the volume of the mass element is $\delta\tau$, so that $\delta m = \rho\delta\tau$.

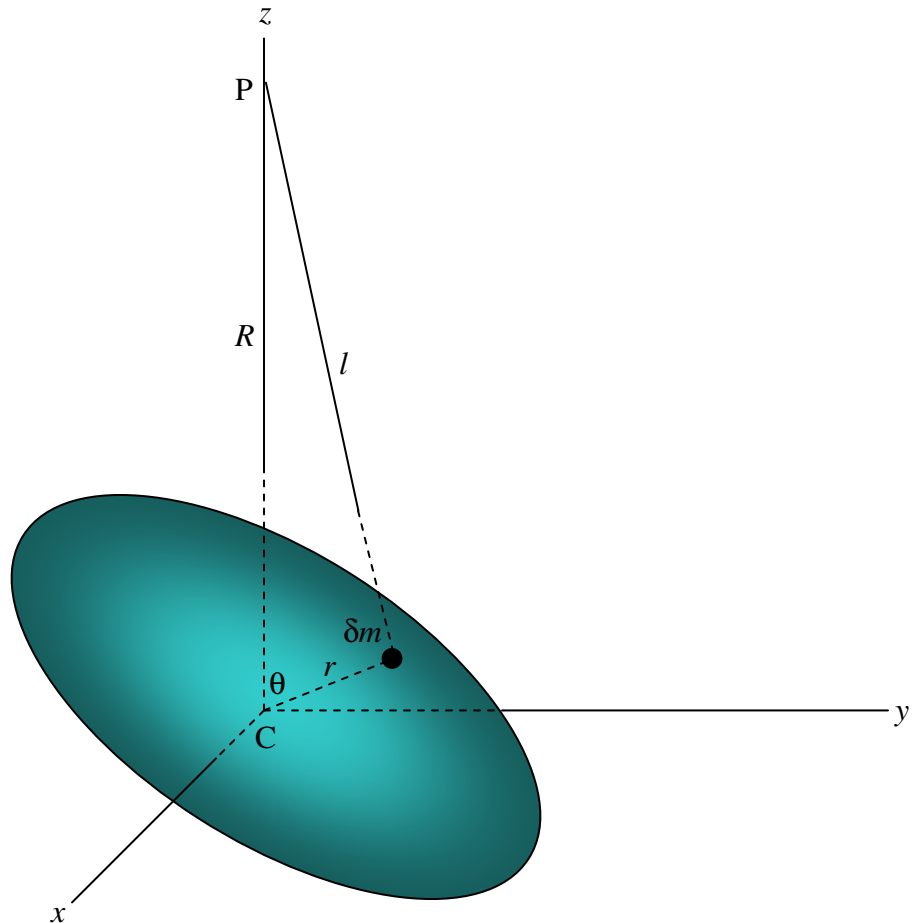

FIGURE V.26

The potential at P is
$$\psi = -G \int \frac{dm}{l} = -G \int \frac{\rho d\tau}{l}. \quad 5.12.1$$

But $l^2 = R^2 + r^2 - 2Rr \cos \theta$,

so

$$\psi = -G \left[\frac{1}{R} \int \rho d\tau + \frac{1}{R^2} \int \rho r \cos \theta d\tau + \frac{1}{R^3} \int \rho r^2 P_2(\cos \theta) d\tau + \frac{1}{R^4} \int \rho r^3 P_3(\cos \theta) d\tau \dots \right]. \quad 5.12.2$$

The integral is to be taken over the entire body, so that $\int \rho d\tau = M$, where M is the mass of the body. Also $\int \rho r \cos \theta d\tau = \int z dm$, which is zero, since C is the centre of mass.

The third term is

$$\frac{1}{2R^3} \int \rho r^2 (3 \cos^2 \theta - 1) d\tau = \frac{1}{2R^3} \int \rho r^2 (2 - 3 \sin^2 \theta) d\tau. \quad 5.12.3$$

Now $\int 2\rho r^2 d\tau = \int 2r^2 dm = \int [(y^2 + z^2) + (z^2 + x^2) + (x^2 + y^2)] dm = A + B + C$,

where A , B and C are the second moments of inertia with respect to the axes Cx , Cy , Cz respectively. But $A + B + C$ is invariant with respect to rotation of axes, so it is also equal to $A_0 + B_0 + C_0$, where A_0 , B_0 , C_0 are the *principal moments of inertia*.

Lastly, $\int \rho r^2 \sin^2 \theta d\tau$ is equal to C , the moment of inertia with respect to the axis Cz .

Thus, if R is sufficiently larger than r so that we can neglect terms of order $(r/R)^3$ and higher, we obtain

$$\psi = -\frac{GM(2MR^2 + A_0 + B_0 + C_0 - 3C)}{2R^3}. \quad 5.12.4$$

In the special case of an *oblate symmetric top*, in which $A_0 = B_0 < C_0$, and the line CP makes an angle γ with the principal axis, we have

$$C = A_0 + (C_0 - A_0) \cos^2 \gamma = A_0 + (C_0 - A_0) Z^2 / R^2, \quad 5.12.5$$

so that
$$\psi = -\frac{G}{R} \left[M + \frac{C_0 - A_0}{2R^2} \left(1 - \frac{3Z^2}{R^2} \right) \right]. \quad 5.12.6$$

Now consider a uniform oblate spheroid of polar and equatorial diameters $2c$ and $2a$ respectively. It is easy to show that

$$C_0 = \frac{2}{5} Ma^2. \quad 5.12.7$$

(*Exercise:* Show it.)

It is slightly less easy to show (*Exercise:* Show it.) that

$$A_0 = \frac{1}{5} M(a^2 + c^2). \quad 5.12.8$$

For a symmetric top, the integrals of the odd polynomials of equation 5.12.2 are zero, and the potential is generally written in the form

$$\psi = -\frac{GM}{R} \left[1 + \left(\frac{a}{R} \right)^2 J_2 P_2(\cos \gamma) + \left(\frac{a}{R} \right)^4 J_4 P_4(\cos \gamma) \cdots \right] \quad 5.12.9$$

Here γ is the angle between CP and the principal axis. For a uniform oblate spheroid, $J_2 = \frac{C_0 - A_0}{Mc^2}$. This result will be useful in a later chapter when we discuss precession.

5.13 Pressure at the Centre of a Uniform Sphere

What is the pressure at the centre of a sphere of radius a and of uniform density ρ ?

(Preliminary thought: Show by dimensional analysis that it must be something times $G\rho^2 a^2$.)

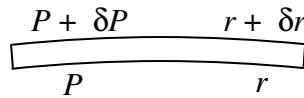

FIGURE V.27

Consider a portion of the sphere between radii r and $r + \delta r$ and cross-sectional area A . Its volume is $A\delta r$ and its mass is $\rho A\delta r$. (Were the density not uniform throughout the sphere, we would here have to write $\rho(r)A\delta r$.) Its weight is $\rho g A\delta r$, where $g = GM_r / r^2 = \frac{4}{3}\pi G\rho r$. We suppose that the pressure at radius r is P and the pressure at radius $r + \delta r$ is $P + \delta P$. (δP is negative.) Equating the downward forces to the upward force, we have

$$A(P + \delta P) + \frac{4}{3}\pi AG\rho^2 r\delta r = AP. \quad 5.13.1$$

That is:
$$\delta P = -\frac{4}{3}\pi G\rho^2 r\delta r. \quad 5.13.2$$

Integrate from the centre to the surface:

$$\int_{P_0}^0 dP = -\frac{4}{3}\pi G\rho^2 \int_0^a r dr. \quad 5.13.3$$

Thus:
$$P = \frac{2}{3}\pi G\rho^2 a^2. \quad 5.13.4$$